

DOCUMENT RESUME

ED 052 931

SE 010 602

AUTHOR Kaprielyan, S. Peter
TITLE Aerospace Management, Volume 5 Number 1.
INSTITUTION General Electric Co., Philadelphia, Pa.
PUB DATE 70
NOTE 130p.
AVAILABLE FROM General Electric Company, Valley Forge Space
Technology Center, P. O. Box 8555, Philadelphia,
Pennsylvania (copy or subscription free)

EDRS PRICE MF-\$0.65 HC-\$6.58
DESCRIPTORS Administration, *Aerospace Industry, *Aerospace
Technology, Management, Physical Sciences, Technology

ABSTRACT

Presented are articles and reports dealing with aspects of the aerospace programs of the National Aeronautics and Space Administration (NASA). Of major concern are the technological and managerial challenges within the space station and space shuttle programs. Other reports are given on: (1) medical experiments, (2) satellites, (3) international cooperation, (4) tracking and data acquisition, (5) managerial objectives, (6) program economics, (7) manpower resources, (8) interagency cooperation, (9) commercial applications, and (10) patents and licensing. (RS)

ED052931

AEROSPACE MANAGEMENT

GENERAL ELECTRIC COMPANY AEROSPACE GROUP

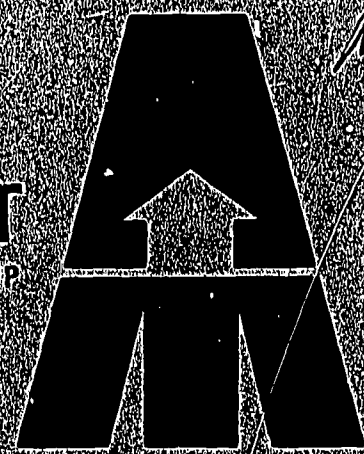

N-X
SE

U.S. DEPARTMENT OF HEALTH,
EDUCATION & WELFARE
OFFICE OF EDUCATION
THIS DOCUMENT HAS BEEN REPRO-
DUCED EXACTLY AS RECEIVED FROM
THE PERSON OR ORGANIZATION ORIG-
INATING IT. POINTS OF VIEW OR OPIN-
IONS STATED DO NOT NECESSARILY
REPRESENT OFFICIAL OFFICE OF EDU-
CATION POSITION OR POLICY.

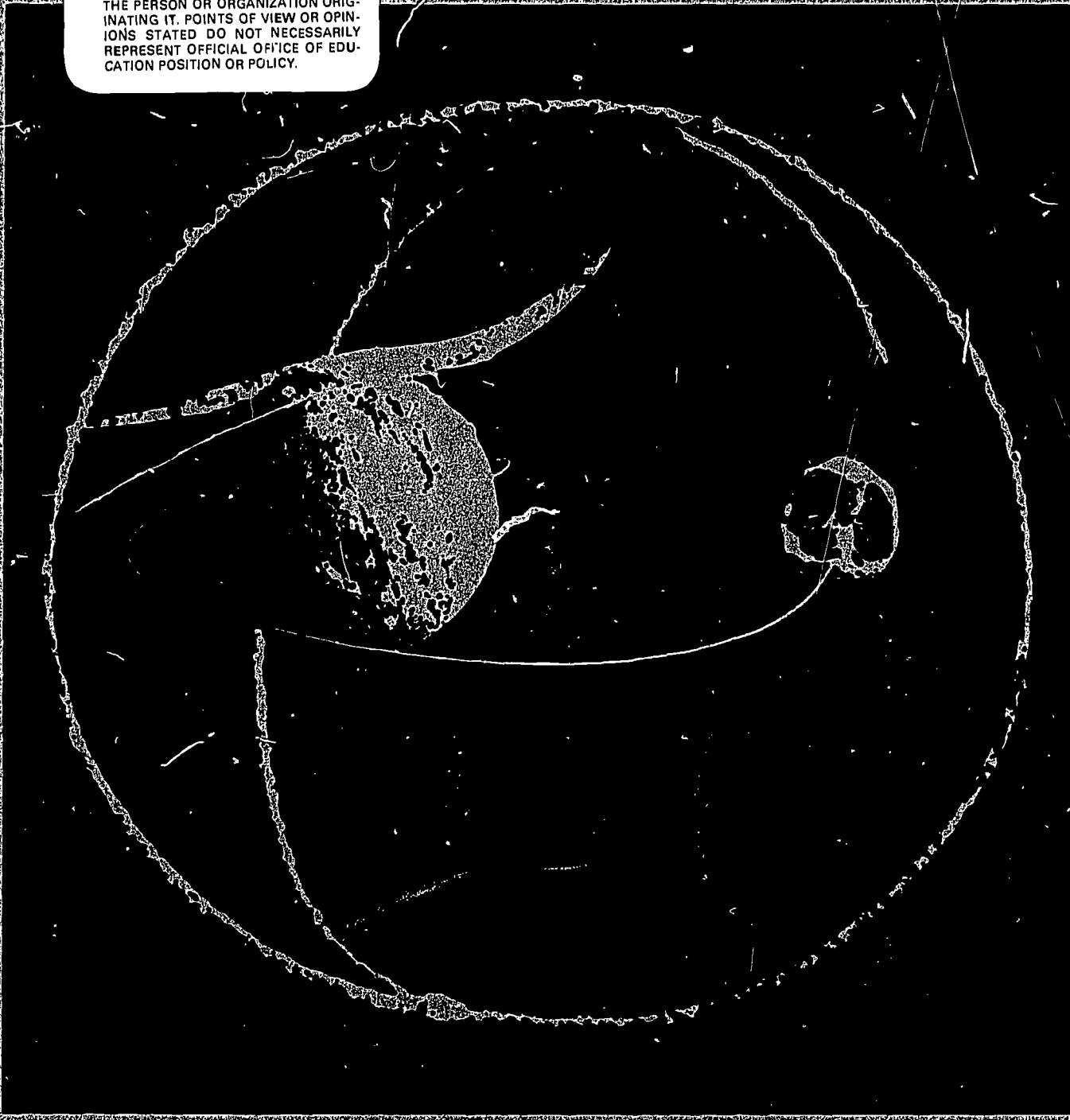

SE NO 602

1970 VOLUME 5 NUMBER 1

NASA'S MAJOR CHALLENGES FOR THE SEVENTIES

ED052931



“... the United States will take positive, concrete steps toward internationalizing man's epic venture into space—an adventure that belongs not to one nation but to all mankind. I believe that both the adventures and the applications of space missions should be shared by all peoples. Our progress will be faster and our accomplishments greater if nations will join together in this effort, both in contributing the resources and in enjoying the benefits.”

(Excerpt from President Nixon's statement on
March 7, 1970, Key Biscayne, Florida)

AEROSPACE MANAGEMENT

GENERAL ELECTRIC COMPANY AEROSPACE GROUP
1970 VOLUME 5 NUMBER 1

GENERAL  ELECTRIC

Manager, Management Practices Section
Space Division
Kenneth O. Chilstrom
Editor
S. Peter Kaprielyan
Art Director
Roy Scarfo
Distribution Manager
Sydney Eckman

Divisional Advisors
Aircraft Equipment Division
Dr. John G. Hutton
Defense Programs Division
Lawrence R. Cohen
Electronic Systems Division
Hugh Mease, Jr.
Re-entry and Environmental
Systems Division
Donald E. Burrus
Space Division
James R. Polski

Mark Morton, Vice President
General Electric Company
Group Executive—Aerospace Group
Charles W. George, Vice President
General Electric Company
General Manager
Aircraft Equipment Division
L. Berkley Davis, Vice President
General Electric Company
General Manager
Defense Programs Division
Dr. Roy H. Beaton, Vice President
General Electric Company
General Manager
Electronic Systems Division
Otto Klima, Vice President
General Electric Company
General Manager
Re-entry and Environmental
Systems Division
Daniel J. Fink, Vice President
General Electric Company
General Manager, Space Division

FEATURES

Page

**ACTIVE ROLE FOR NASC SEEN IN 70S
BY AGENCY'S EXECUTIVE SECRETARY** 9
*Interview with William A. Anders
Executive Secretary, National Aeronautics and Space Council*
Under charter provided by 1958 Space Act to National Aeronautics and
Space Council energetic former astronaut aims at broadening
agency's problem-solving capabilities

CONCEPTS FOR SPACE STATION & SHUTTLE SHAPING UP FROM STRENGTHS OF CENTERS

Viewpoints from NASA Headquarters on the technological and man-
agerial challenges of the manned space-flight programs of the Seventies,
their scope and significance, and facets of organizational roles.

**POST-APOLLO MANNED OPERATIONS
CENTER ON MAXIMIZING RETURNS** 16
*Dr. Wernher von Braun
Deputy Associate Administrator for Planning*

**AN OVERVIEW OF THE SKYLAB,
STATION AND SHUTTLE ROLES** 23
*Charles W. Mathews
Deputy Associate Administrator, Office of Manned Space Flight*

**SPACE SHUTTLE REQUIREMENTS,
PROGRAM PLANS AND PROGRESS** 29
*Dale D. Myers
Associate Administrator for Manned Space Flight*

**SPACE STATION OBJECTIVES,
OPERATION AND APPLICATIONS** 35
*Dale D. Myers
Associate Administrator for Manned Space Flight*

**OART WORK TOWARD SHUTTLE,
AND RESEARCH HIGHLIGHTS** 41
*Oran W. Nicks
Acting Associate Administrator for Advanced Research and Technology*

**OART WORK TOWARD STATION—
TECHNOLOGICAL CHALLENGES** 50
*Oran W. Nicks
Acting Associate Administrator for Advanced Research and Technology*

**DEVELOPING THE TECHNOLOGICAL
BASE FOR THE SPACE SHUTTLE** 58
*Adelbert O. Tischler
Director, Chemical Propulsion Division, OART*



AEROSPACE MANAGEMENT, a publication of General Electric's Aerospace Group, is provided as a forum for the exchange of system/project management concepts, techniques and practices evolving in the government, the industry and their interface. The opinions expressed or implied in this publication are private, and do not necessarily represent the views of the General Electric Company. AEROSPACE MANAGEMENT is produced by the Space Division's Management Practices Section, of the Finance and Contract Management Operation, Room M-3128; Valley Forge Space Technology Center, P. O. Box 8555, Philadelphia, Pa. Tel. 215-962-3040.

(Table of contents continued)

FEATURES	Page
AIM OF MEDICAL EXPERIMENTS PROGRAM: TO BETTER KNOW EARTH-MAN IN SPACE	63
<i>Interview with Dr. Sherman P. Vinograd Director, IMBLMS Program and Research and Technology</i>	
Broad Medical/Behavioral Experiments Program for evaluating human system changes induced by space flight may advance diagnosis and therapy in Earth's environment	
OSSA'S R&D TASKS TOWARD SEVENTIES STRESS SATELLITES FOR SERVING MAN	73
<i>Interview with Dr. John E. Naugle Associate Administrator for Space Science and Applications</i>	
Despite NASA budget decrease over recent years, the budget of the Office of Space Science and Applications has continued to increase, with emphasis on applications	
COOPERATIVE INTERNATIONAL VENTURES OF 60S FORM BASES FOR BENEFICIAL PROGRAMS OF 70S	81
<i>Interview with Arnold W. Frutkin Assistant Administrator for International Affairs</i>	
Extensive participation of international scientific community in U.S. space efforts provides prototypes for applications programs oriented to the global needs of man	
OFFICE OF TRACKING & DATA ACQUISITION MAINTAINS LIFELINES TO SPACE MISSIONS	93
<i>Interview with H. R. Brockert Deputy Associate Administrator for Tracking and Data Acquisition</i>	
NASA's three specialized communication networks around the world provide the vital links between Earth and spacecraft, to render mission support and gather space data	
MANAGERIAL PERSPECTIVES ON 70'S NEEDS PROJECT TREND OF EVOLUTIONARY CHANGES	101
<i>Interview with Bernard Moritz Acting Associate Administrator for Organization and Management</i>	
High selectivity in choosing goals and management tools, sharper focus on system objectives and requirements characterize NASA's austere approach to the Seventies	
"ECONOMY THROUGH CONSCIENTIOUS HOMEWORK"	104
<i>Interview with William E. Lilly Assistant Administrator for Administration</i>	
"REVITALIZING NASA'S MANPOWER RESOURCES"	107
<i>Interview with Grove Webster Personnel Division Director, Office of Administration</i>	
NASA'S MULTIPLE INTERAGENCY INTERFACES BLEND KNOW-HOW TOWARD COMPLEX PROGRAMS	111
<i>Interview with General Jacob E. Smart, USAF (Ret.) Assistant Administrator for DOD and Interagency Affairs</i>	
Extensive experience integrating efforts and resources needed for managing complex endeavors, provides useful insights for coping with coming challenges	
NASA'S OFFICE OF TECHNOLOGY UTILIZATION FEEDS USEFUL CONCEPTS TO PUBLIC SECTOR	119
<i>Interview with Melvin S. Day Acting Assistant Administrator for Technology Utilization</i>	
Wide variety of specialized publications and information centers make findings from space-oriented technology accessible to commercially-oriented entrepreneurs	
PATENTS AND LICENSING POLICY	126
<i>Interview with Gayle Parker Patent Attorney, Office of General Counsel, NASA Headquarters</i>	

Cover Motif: An interpretation of NASA symbol, from a sculpture by Billy Newman, West Chester, Pa.

RIPENING OPPORTUNITIES FOR GLOBAL COOPERATION

We take pleasure in devoting this issue of our publication to discussions highlighting NASA's major challenges for the Seventies, from the perspective of a representative group whose members have played distinguished roles in structuring the successful space programs of the Sixties. From this experience stem the thoughts, synopsized on these pages, on the beneficial uses of man's developing skills and tools in a newly-accessible realm, of dimensions to match his imagination.

The many momentous events and valiant deeds of the last decade leave us a legacy of vital technological progress, which formerly was the concomitant only of global conflicts.

We are proud to be an active part of an industrial community which contributed to the development of a new level of national competence in the last decade, with attendant benefits to the economy and national prestige; and we welcome the opportunities presented by the current decade for directing this newly-acquired competence toward the improvement of the conditions of life on our planet.

On a planet moving in a universe ruled by a diversity of scarcely-understood forces, new science and technology provide for man insights on aspects of reality which relate directly to his comfort, sustenance, and survival. These insights, be they newly-discovered truths or novel tools, serve to extend the dimensions of his consciousness, and to augment his powers to shape his destiny. As attested by the record of human events, the societies which have failed to appraise this vital tenet of existence have either been overcome by their more vigorous contemporaries, or have withered in their neglect.

A simplistic notion is swelling in our nation today tending to discredit science and technology, and to ascribe to

them the host of social ills that are now impinging on human consciousness. And through fatuous discrediting of the role and beneficial aspects of science and technology we are losing sight of the very potentials of our new scientific tools and methods that may serve us in seeking answers to our dilemmas. In the wake of a most remarkable decade of achievements we can ill-afford to lapse back into the innocence and technological torpor of pre-Sputnik days; we may never have the luxury of a second start in this eventful century.

Is it not significant that many of the dilemmas of the human condition — which we now consider in conflict with man's higher aspirations, and hence insufferable — were, not so long ago, still accepted as part of the human lot on this planet? Is it not also noteworthy that this change in attitude and aspirations became more pronounced in this era of space exploration — the high bench mark of science and technology?

In the first decade of space achievements, it was vigorous international competition which motivated man to reach the moon and the thresholds of the planets. Today, in the second decade, unprecedented opportunities are beckoning to motivate man to work with his fellowman, endowed with vision from a new perspective — a perspective which makes political boundaries recede into imperceptibility... oceans and continents to coalesce into the outline of a tiny, blue, and beautiful planet... and many of its major problems to merge into the challenges common to the diminutive community of man.

Dare we fail to grasp the significance of this moment, and be negligent in fulfilling the promise of its unequalled opportunities?



Daniel J. Fink

Daniel J. Fink, Vice President
General Electric Company
General Manager, Space Division

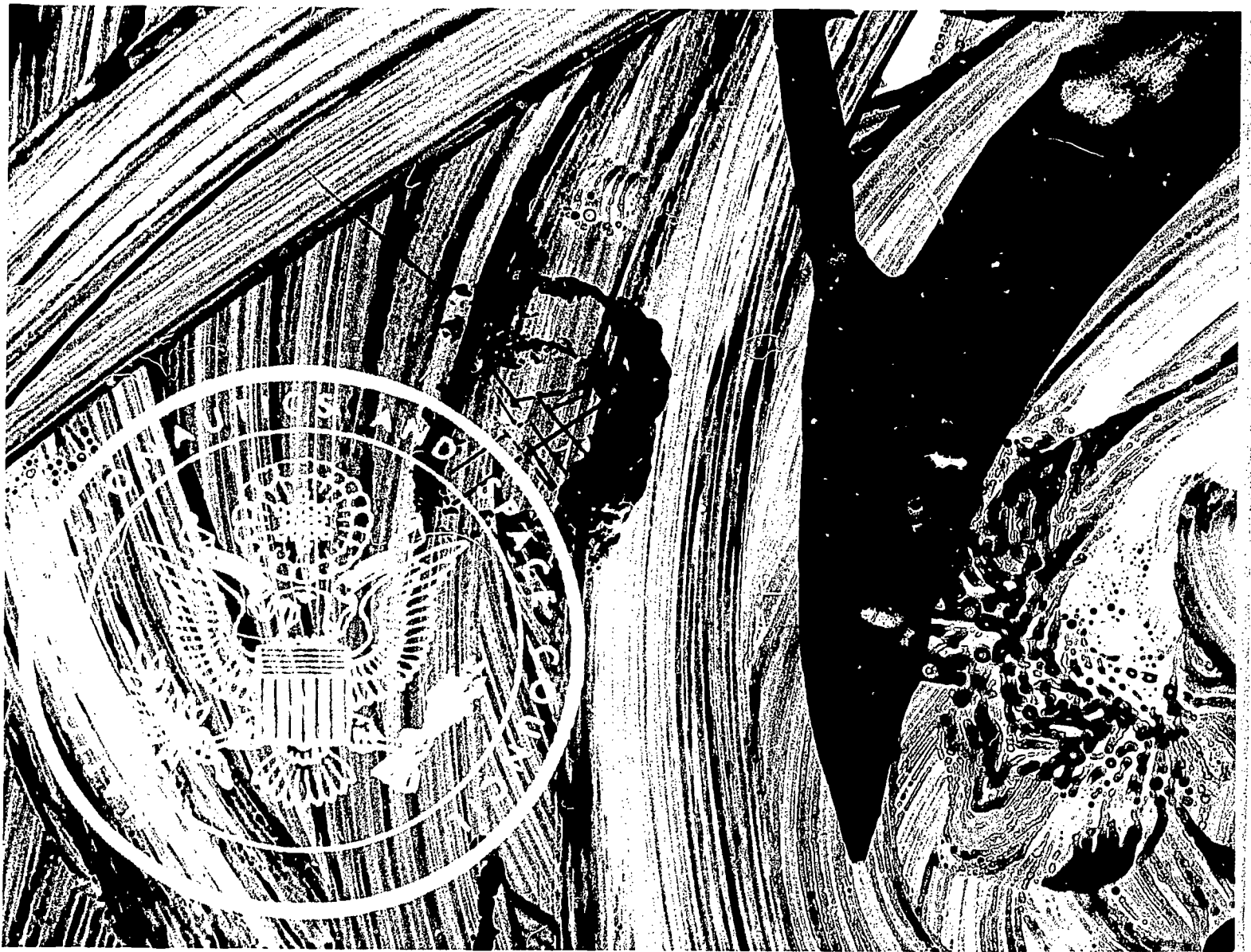

ACTIVE ROLE FOR NASC SEEN IN 70S BY AGENCY'S EXECUTIVE SECRETARY



Interview with William A. Anders*
Executive Secretary, National Aeronautics and Space Council

Under charter provided by 1958 Space Act to National Aeronautics and Space Council energetic former astronaut aims at broadening agency's problem-solving capabilities

Historians of the future who focus their hindsight on the signal documents of this century, are likely to pick PL 85-568 as the epochal piece of legislation that led the U.S. into the space age.

Better known as the National Aeronautics and Space Act of 1958, this 43-page declaration constitutes in effect the combined birth certificate of the National Aeronautics and Space Council (NASC) and the National Aeronautics and Space Administration (NASA). Congress has amended the basic Space Act from time to time, to keep it up to date with changing circumstances. The National Aeronautics and Space Council includes: the Vice President as Chairman, the Secretaries of State and Defense, the Chairman of the Atomic Energy Commission, and the Administrator of the NASA. The Secretary of Transportation is also invited to participate whenever discussions bear on aeronautics. As the Council's Executive Secretary, I am responsible for the development and direction of the advisory staff.

It's unfortunate, in a way, that names and designations which are lengthy often tend to get telescoped in usage to the point of losing identity. As a descriptive identity, the once significantly structured name of National Aeronautics and Space Council has gradually eroded into that of "Space Council." I feel that this transfiguration has been insidiously detrimental to the original purpose and policy of this Council. That is, the shedding of the qualifier "National" has deemphasized the Council's charter and character, and the muting of the term "Aeronautics" has tended to weight the Council's apparent orientation singularly toward "Space."

Perhaps in the period leading up to

*Crew member of APOLLO 8—manned by astronauts Frank Borman, James A. Lovell, Jr., and William A. Anders—launched on December 21, 1968, which became the first manned spacecraft to orbit the moon.



"As a descriptive identity, the once significantly structured name of National Aeronautics and Space Council has gradually eroded into that of 'Space Council.' I feel that this has been detrimental to the original purpose and policy of this Council."

the lunar landings it was appropriate to have a more narrowly directed national orientation. But now that we have attained our initial objective of manned lunar exploration, we should broaden our aims toward a wider spectrum of aero-space competence. President Nixon's statement of March 7 at Key Biscayne stressed the importance, for our nation, of adopting a "bold and balanced" approach to space exploration. This concept of a balanced approach is inherent also to

the Act which provides the charters of the NASC and NASA. Here's some of the specific wording of the legislation that states NASC's reason for being:

"It shall be the function of the Council to advise and assist the President, as he may request, with respect to the performance of functions in the aeronautics and space field, including the following functions:

(1) Survey all significant aeronautical and space activities, including the



"Located as it is, close to the political pulse of the nation, the Council's orientation could easily be political rather than technical. It is my intention to make a strong technical and policy orientation prevail. For I believe it is primarily through this kind of orientation that we can hope to render our country's aerospace activities most relevant to some of the major problems we are facing as a nation."

policies, plans, programs, and accomplishments of all departments and agencies of the United States engaged in such activities;

(2) Develop a comprehensive program of aeronautical and space activities to be conducted by departments and agencies of the United States;

(3) Designate and fix responsibility for the direction of major aeronautical and space activities;

(4) Provide for effective cooperation among all departments and agencies of the United States engaged in aeronautical and space activities, and specify, in any case in which primary responsibility for any category of aeronautical and space activities has been assigned to any department or agency, which of those activities may be carried on concurrently by other departments or agencies; and

(5) Resolve differences arising among departments and agencies of the United States with respect to aeronautical and space activities under this Act, including differences as to whether a particular project is an aeronautical and space activity."

What this implies, in essence, is that the NASC is a Cabinet-level organization that looks at aerospace activities — and makes policy recommendations to the President as the ultimate decision-maker. So in my position as Executive Secretary of the NASC I must view the nation's aerospace activities through the President's eyes, so to speak, in order to help determine what needs to be done to serve national interests in aeronautics and space — consistent with other priorities. Considering the swift pace of advances in these fields, this task of the NASC is of a self-renewing nature. This was reflected in part in the Space Task Group Report to the President (September 1969) with a closing statement to the Conclusions and Recommendations, as follows:

"The environment in which the space program is viewed is a vibrant, changing one and the new opportunities that tomorrow will bring cannot be predicted with certainty. Our planning for the future should recognize this rapidly changing nature of opportunities in space.

"We recommend that the National Aeronautics and Space Council be utilized as a mechanism for continuing reassessment of the character and pace of the space program."

Key Role of Space Task Group

Starting with the mid-Sixties, when each success of the Gemini Program was bringing the Apollo Program a building block closer to reality, the concern of the aerospace community was turning to the uncharted region of post-Apollo goals. Eventually, with the approaching lunar landing, the need to establish new space goals ripened. To his credit, Dr. Lee A. DuBridge, science adviser to President Nixon, early in 1969 suggested the formation of a Space Task Group to make definitive recommendations on the future direction of the U.S. space program. Thus at the President's request a Space Task Group was assembled, under the chairmanship of Vice President Agnew, composed of Dr. Robert C. Seamans, Secretary of the Air Force; Dr. Thomas O. Paine, Administrator, NASA; Dr. DuBridge; Dr. U. Alexis Johnson, Under Secretary of State for Political Affairs; and Dr. Glenn T. Seaborg, Chairman, Atomic Energy Commission; with Dr. Robert P. Mayo, Director, Bureau of the Budget, and Dr. DuBridge as observers. The report of the Space Task Group made to the President in September 1969 — as I began my assignment — provided the bases for Mr. Nixon's announcement, on March 7 of this year, for a "bold and balanced" U.S. Space Program for

the Seventies. And what has been made clear regarding the "balanced" approach to future efforts in space is that, as stated by the President, our Space Program should be directed (1) to achieve manned exploration, (2) to acquire scientific knowledge, and (3) to yield practical applications for improving the conditions of life on Earth.

Thus the Space Task Group has fulfilled its vital catalytic function, and the U.S. Space Program has acquired its objectives for the Seventies. It is now the management challenge of the NASC to continually review the course of the Space Program charted by the President, and to implement national policy and coordination decisions toward the established objectives. The NASC charter provided by the Space Act of 1958 is actually quite broad and adequate for carrying out these tasks.

Staffing of the Top Team

One of my first concerns, after being appointed as Executive Secretary of the NASC, was to meet with the Vice President and traditional Chairman of the Council, as well as with the other members and the Executive Office, regarding what I should do in my new position. There was general agreement that I should work to develop a competent staff which would assist in providing and maintaining the new direction of the Space Program. With general guidance from the Vice President, and considerable latitude to implement the Council's charter I'm now in process of developing initial candidate policy issues for possible Council consideration.

My initial concern was to bring together a small group of civilian and military experts, from various fields of aerospace activity, to solidify a broad



"As implied by our charter, our basic mission is to broadly coordinate the technical aspects of aeronautics and space, ultimately for the general welfare and security of the United States."

spectrum of capability in the eyes of the Executive Office. The functions and responsibilities of our staff require a considerably broad viewpoint; we need to keep our sights on the overview and not get mired in minutiae. We must, however, be also capable of focusing attention on so-called nuts-and-bolts aspects, should these appear to be of significance in the greater scheme of things.

Located as it is, close to the political pulse of the nation, the Council's orientation could easily be political rather than technical. It is my intention to make a strong technical and policy orientation prevail. For I believe it is primarily through this kind of orientation that we can hope to render our country's aerospace activities most relevant to some of the major problems we are facing as a nation. It is also my intention to make certain that an environment benevolent to aeronautics is maintained, so as to prevent technological lags in this field.

Policy Needed on Aeronautics

The Space Task Group prescribed certain directions for the post-Apollo Space Program, and the President translated these into goals. As such, we have fairly well-delineated guideposts to our near-term objectives in space; we shall reassess these on a yearly basis to determine our progress. But we have no equally clear national direction or policy on aeronautics. The NASC will work toward the definition of our national objectives in this respect.

Among the promising concepts of aeronautics close to realization, for example, is that of short take-off and landing (STOL) aircraft. Yet the development of this concept to the point of practicality seems to be stymied, at the moment, by the consideration of

needs versus facilities. From the wealth of technological advances made in the process of exploring space, there must undoubtedly exist a host of developments of potential application to aeronautics. I'm sure I'm not alone on this aspect of technology transfer, nor in feeling the need to bolster our R&D in aeronautics. Similar feelings were expressed, earlier this year, during a session of the House Subcommittee on Advanced Research and Technology, with recommendations that the United States establish a national aeronautics and aviation policy emphasizing R&D toward the solution of some major aviation problems, including: avionics, propulsion, noise suppression, instrumentation, turbines and compressors, man-machine relationships, air traffic control and air congestion.

As implied by our charter, or basic mission is to broadly coordinate the technical aspects of aeronautics and space, ultimately for the general welfare and security of the United States. This is, then, a function that will depend greatly on effective communication among and with the intricate network of government agencies. We have developed a comprehensive list of organizations and individuals, in the government, which have an interest in aeronautics and space; we are now establishing a procedure to assure the active and bilateral flow of information.

We are facing a spectrum of technological and managerial challenges, both in aeronautics and space, which are of national relevance and significance. As a policy-development team of the Executive Branch, the NASC is provided with a unique vantage point for the consideration of unusual problems, and also with the opportunities to recommend viable and achievable alternatives, to the President, for their solution. **A**

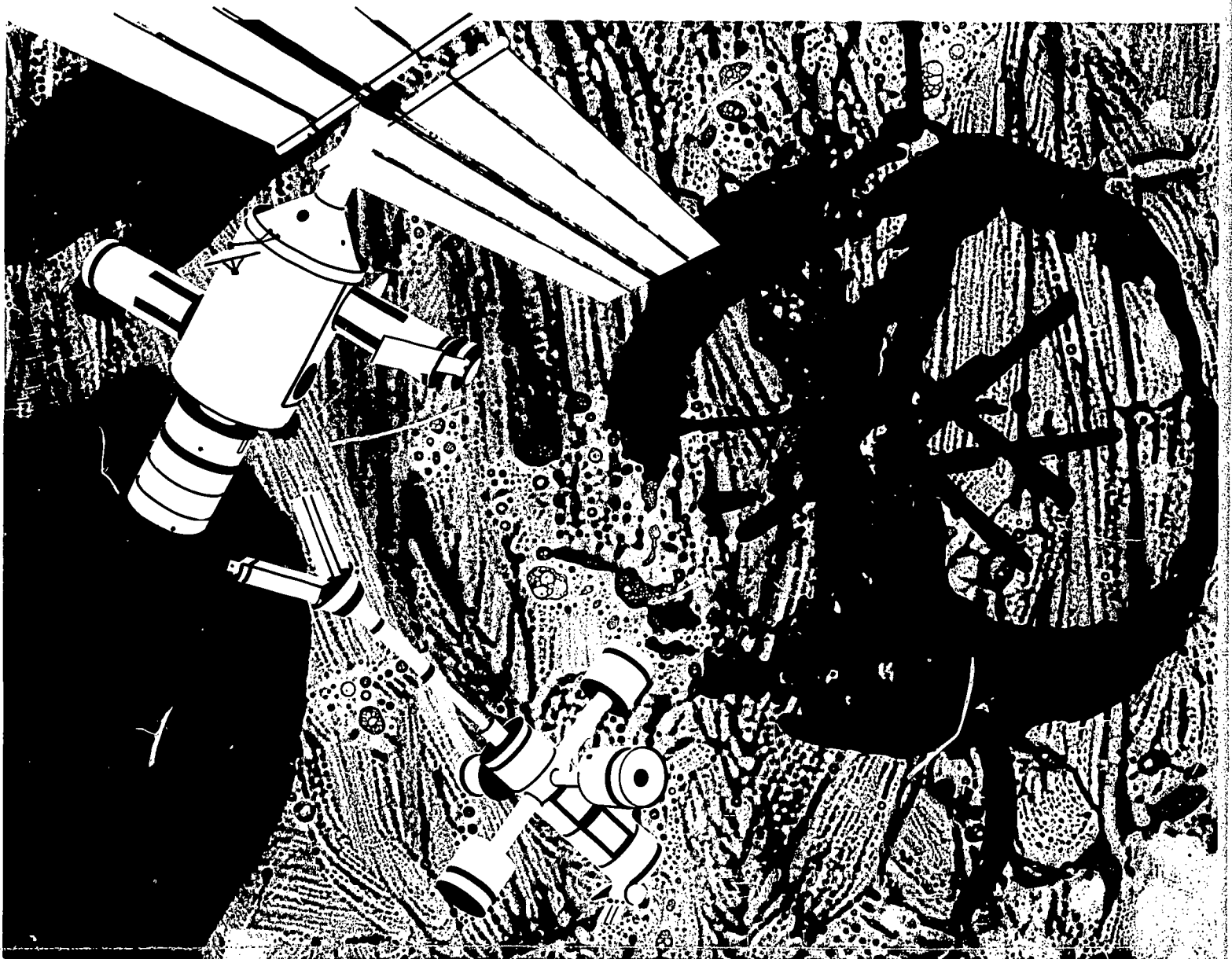

CONCEPTS FOR SPACE STATION & SHUTTLE SHAPING UP FROM STRENGTHS OF CENTERS

Viewpoints from NASA Headquarters on the technological and managerial challenges of the manned space-flight programs of the Seventies, their scope and significance, and facets of organizational roles, by the following:



*Dr. Wernher von Braun,
Deputy Associate Administrator for Planning*



*Charles W. Mathews
Deputy Associate Administrator, Office of
Manned Space Flight*



*Dale D. Myers
Associate Administrator for Manned Space Flight*



Oran W. Nicks
Acting Associate Administrator for Advanced
Research and Technology*



*Adelbert O. Tischler
Director, Chemical Propulsion Division
Office of Advanced Research and Technology*

*Presently, Deputy Director of the NASA Langley Research Center.

POST-APOLLO MANNED OPERATIONS CENTER ON MAXIMIZING RETURNS

Dr. Wernher von Braun
Deputy Associate Administrator for Planning

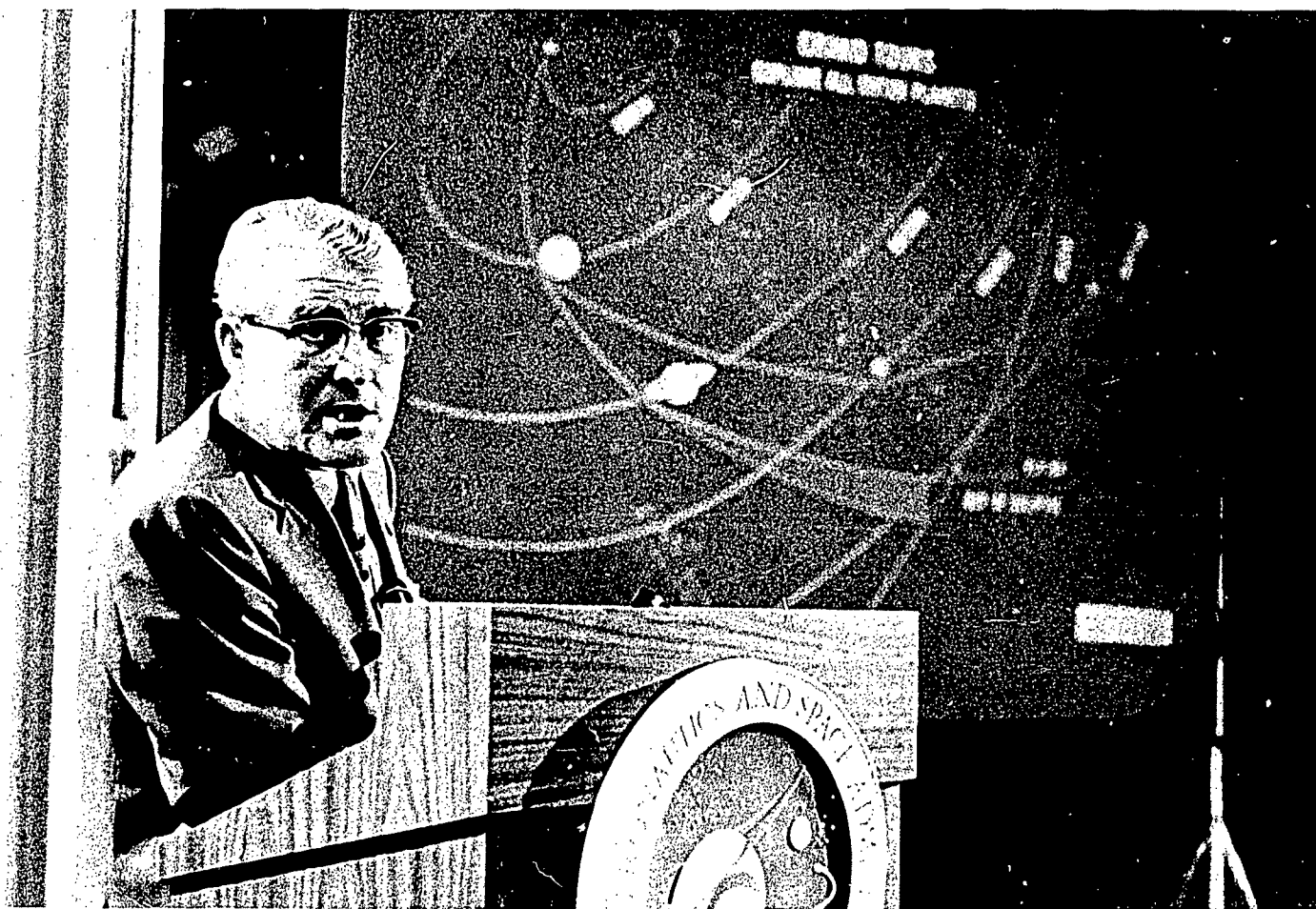

"The first science and applications work in orbit, supported by astronaut-scientists, will begin in 1972 with the launching of the Skylab. The Skylab Program (known previously as the Apollo Applications Program) will make maximum use of Apollo Program experience and hardware for the conduct of space science and applications work."

Dr. von Braun heads the NASA Planning Board which was formed, on May 4, 1970, to integrate and centralize the agency's planning activities, and to serve in an advisory capacity to the Administrator.

Charged with the NASA-wide integration of aeronautics and space program planning, this Board and its activities are supported by a central staff under Dr. von Braun and Dr. DeMarquis D. Wyatt, Assistant Administrator for Planning. The Board's function is to oversee and supplement the planning performed by all NASA line offices.

In the heydays of Apollo, we had a very simple and clear charter to land a man on the moon in the Sixties and bring him back alive. So there was very little talk about goals and objectives in manned space flight. The goals and objectives were stated back in 1961, and had never changed.

In the post-Apollo 11 environment, we shall have to make the applications and the science returns justify and pay for a good part of the space program. Unless we can prove to the participating scientists, the people on the street, and to our "customer" agencies that the space program is really useful for them, we will find it increasingly difficult to retain their continued support.

The first science and applications work in orbit supported by astronaut-scientists will begin in 1972 with the launching of the Skylab. The Skylab Program (known previously as the Apollo Applications Program) will make maximum use of Apollo Program experience and hardware for the conduct of space science and applications tasks.

The first Skylab flight will be unmanned, boosted by a two-stage Saturn V. Only the first and second stages will be live Saturn V stages. The third stage is replaced by what we used to call the Orbital Workshop and what we now call the Skylab. The Skylab will be this country's first manned orbital space station.

Attached to this Skylab will be an Airlock Module (AM) and a Multiple Docking Adapter (MDA), to which arriving Command and Service Modules dock for crew exchange. Also attached to it will be the ATM — the Apollo Telescope Mount, a manned solar observatory serviced by the astronaut-scientists living in the Skylab.

One day after the Skylab with its attached modules has been launched into orbit (and has deployed the solar

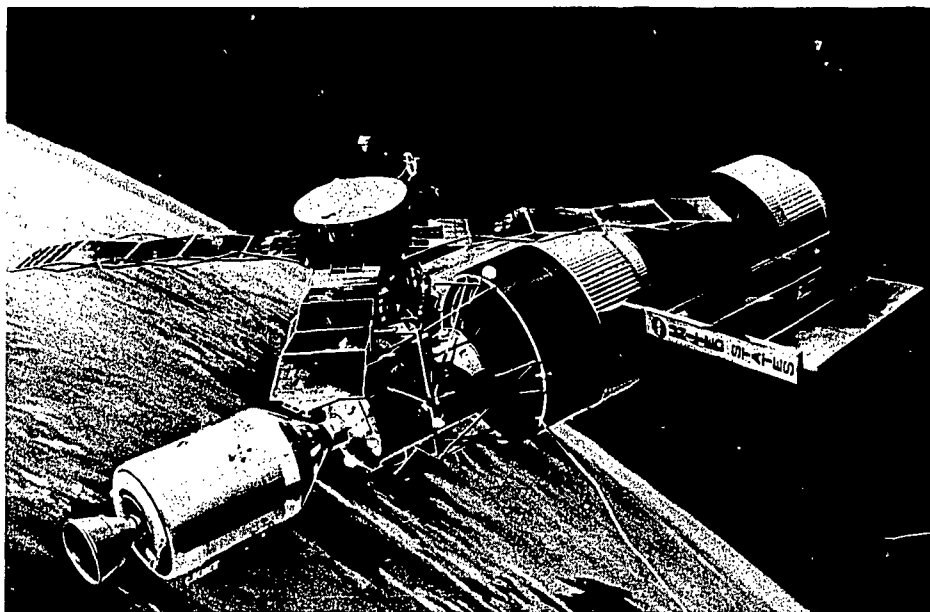

Artist's concept depicting Skylab in Earth orbit.

panels both of the ATM and Skylab itself), it will be visited by a Saturn IB-launched Command and Service Module, manned by the first Skylab crew complement of three.

The Command Module docks with the Multiple Docking Adapter, and the crew slips through the Docking Adapter and the Airlock Module into the Skylab which provides quarters for them. The first crew will stay up there for 28 days. This is about twice as long as the longest flight so far — that of Gemini 7 — where Frank Borman and Jim Lovell orbited the earth for 14 days.

After the 28 days are over, the three men will crawl back into their Command Module, detach the CSM from the MDA, and use the Service Module propulsion system to deboost themselves back into the atmosphere. Prior to reentry, the Command Module will detach itself from the Service Module. It will then go through the usual airbraking sequence and make a nor-

mal Apollo parachute landing.

About three months after the first flight, another flight will go up. This time the crew will stay in the Skylab for 56 days.

Finally, there will be a third visit, again of 56 days, after which the third crew will descend. The Skylab will then go into storage. It can be reactivated thereafter for a few more revisits, if desired.

Second Generation Station

The Skylab will be this country's first Space Station. We hope it will be succeeded by a modularized long-life Space Station, which will come in the late Seventies. This station will in all likelihood be 33 feet in diameter, and each module will be capable of accommodating a total of twelve people. The modules can be stacked together, and the Station can grow as more modules are brought up.

Space Shuttle

To transfer equipment and personnel between the Earth and this permanent Space Station, a Space Shuttle will be used. The development of this Shuttle is, of course, one of the most exciting and at the same time one of the most difficult problems NASA is about to tackle. In the Saturn V, as in all other launch vehicles used thus far, we have thrown all our rocket stages away as we went up into orbit, and onto the moon. This, of course, is a very costly operation.

So the obvious idea occurred: can one not build a completely reusable vehicle that can fly into orbit and return, like an airplane, to be refueled and fly again; a vehicle that can do that maybe a hundred times?

Well, with presently available propellants, including liquid hydrogen/liquid oxygen, any idea of building a one-stage-to-orbit vehicle doesn't look very promising. I'm not saying that it cannot be done, but our studies indicate that all one-stage-to-orbit designs are very marginal and so sensitive with respect to weight and performance assumptions that you'd lose all your payload if you stay just a little bit too far on the optimistic side. And we just don't know enough about such vehicles to be able to say with certainty that our present technology permits us to build a single-stage-to-orbit vehicle with a reasonable payload.

So all our studies indicate that we seem to need a two-stage-to-orbit vehicle. It could take the form of a big rocket-powered airplane, the "booster," to which a smaller rocket plane, the "orbiter" would be side-strapped. The unit would take off vertically. At about Mach number 9 the propellant tanks of the booster would be depleted. At this point, the booster would peel off and the reusable orbiter would be ignited.



"The development of the Space Shuttle is one of the most exciting and most difficult problems NASA is about to tackle."

During its deceleration to subsonic speed, the booster would perform a U-turn and, with the help of air-breathing jet engines, return to the launch site where it would land airplane fashion. Only the reusable orbiter would reach orbit. It would get into orbit with its payload and enough propellant left for the return flight. To return, it would deboost itself back into the atmosphere for an aerodynamic deceleration and a subsequent airplane-type landing.

All-out vs Piecemeal Approach

A reusable booster and a reusable orbiter is, of course, an all-out solution. One could conceivably argue: "Let's not go all-out; let's at first just aim for a reusable orbiter." Even here one has several options. For example,

one could envision a returnable airplane-type spacecraft that is boosted to orbit, either with an all-solid booster or with something like a Titan III, a large liquid rocket, to which a number of solids are strapped. The liquid fuel Titan core itself could be a two-stage vehicle. In this case we would get a throw-away multi-stage booster with a reusable orbiter. We could also use one or two stages of the Saturn V to help get the reusable spacecraft into orbit. Needless to say, any such half-expendable, half-reusable vehicle would only be an interim solution that could never compete in recurrent flight costs with a fully reusable system.

On the other hand, it may still be too early to say which development route, all-out or piecemeal, should be chosen toward the ultimate objective. Clearly, as far as recurrent cost is concerned, a completely reusable system will be more cost effective. Once you have a reusable two-stage vehicle, it seems that you could make one flight to orbit for something like \$5 million. Of this, about one-half would probably be for amortization of the machine. So, if your two-stage vehicle were capable of making 100 flights, but costs \$250 million to build — then you would have to charge \$2.5 million depreciation per flight.

Reusable orbiters launched by discardable rocket-stages are undoubtedly more costly to launch to orbit just because during each flight you would throw the rocket stages away. But the initial non-recurrent cost to develop such a hybrid machine would be substantially less than that leading toward a completely reusable two-stage system.

Question of Returns

And so one of the crucial questions we are presently wrestling with in NASA is this: will the traffic that can



"Once you have a reusable two-stage Shuttle system, it seems that you could make one flight to orbit for something like \$5 million. Of this, about one-half would probably be for amortization of the machine."

be expected in the next 10 or 15 years justify an initial multi-billion dollar outlay to develop a completely reusable Shuttle vehicle? Can we expect that the drastic reduction in orbital flight cost and the Shuttle's ability to be used almost like an airplane will attract enough new space business to justify this kind of an investment? Or would we be smarter to go only half way by limiting our objective to a reusable orbiter thereby foregoing the chance of a drastic fare reduction? Should we stick to throw-away boost stages for a while and tackle a reusable booster later? Or should we possibly build only a reusable booster at first, and inject the manned or unmanned spacecraft into orbit with a discardable second stage?

There is also the question of practical feasibility of building at once a very large two-stage reusable Shuttle, considering the state of the art. Some people seem to believe that it would be smarter to develop a smaller reusable spacecraft first and use this to learn how to build a large one.

The question of optimum payload size and weight for the Shuttle has not yet been settled, anyway. Some people favor smaller vehicles because, as the logic goes, a smaller vehicle would make more flights to move any given total traffic volume. And it is in the very nature of a reusable Shuttle vehicle, of course, that it loses money while it's sitting on the ground — just like an airliner.

This is the point in favor of smaller Shuttles. The argument in favor of larger payloads is that a substantial portion of future traffic will be to very high orbits, in particular Earth-synchronous orbits. In order to get even a modest unmanned payload to synchronous orbit (with the help of an extra high-speed stage), the Shuttle's low orbit payload capability must be quite high.

There are lots of market studies

going on in that area — what will the market spectrum for orbital flights really be? It is almost like an airline trying to find out what type airplane to acquire for its particular route structure. Only an airline knows what its route structure is; we don't.

Figure 1 shows several types of Shuttle concepts presently under study.

Mode of Operation

Figure 2 shows how the completely reusable vehicle would work in principle. After the booster peels off, it makes a high angle-of-attack reentry, while turning back to base. Its air-breathing cruise engines enable it to fly back to the launch site.

The orbiting vehicle goes all the way into orbit. It first enters a 100 nautical mile orbit from which it can make a Hohmann transfer to a higher orbit. Here it can stay up to two weeks. To return, it deboosts back into the atmosphere for aerodynamic braking and descent. The orbiting vehicle probably does not need air-breathing engines because the departure from orbit can be timed so the landing area on the rotating Earth rolls into the footprint area. There is still some question with respect to the need for go-around capability, or at least an ability to provide for a powered approach.

Possible Applications

Regardless of whether the booster is reusable or not, the upper end, the orbiting element, will probably look something like the vehicle shown in Figure 3. Now this configuration would give us over a thousand miles cross-range, which seems to be desirable for some applications. If a hundred miles cross-range is sufficient, the orbiter could have straight wings instead.

SPACE SHUTTLE APPLICATION CONCEPTS

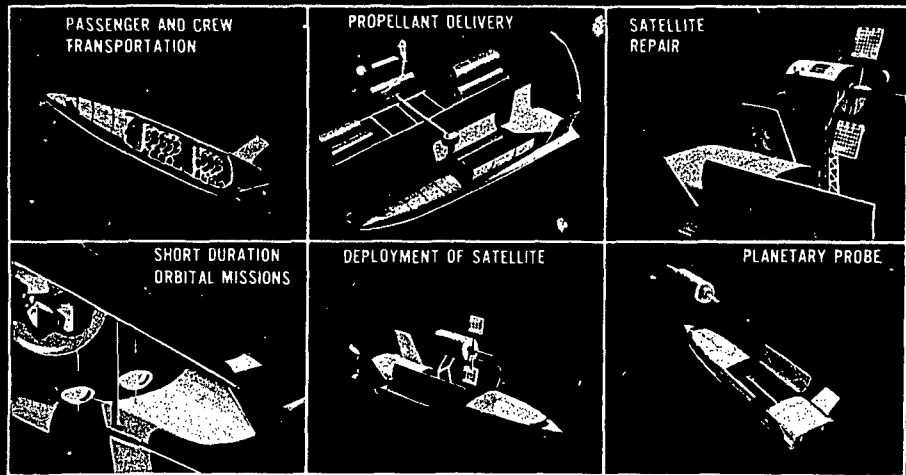
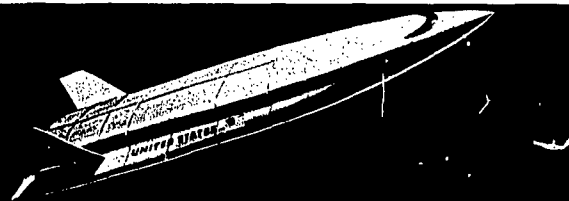
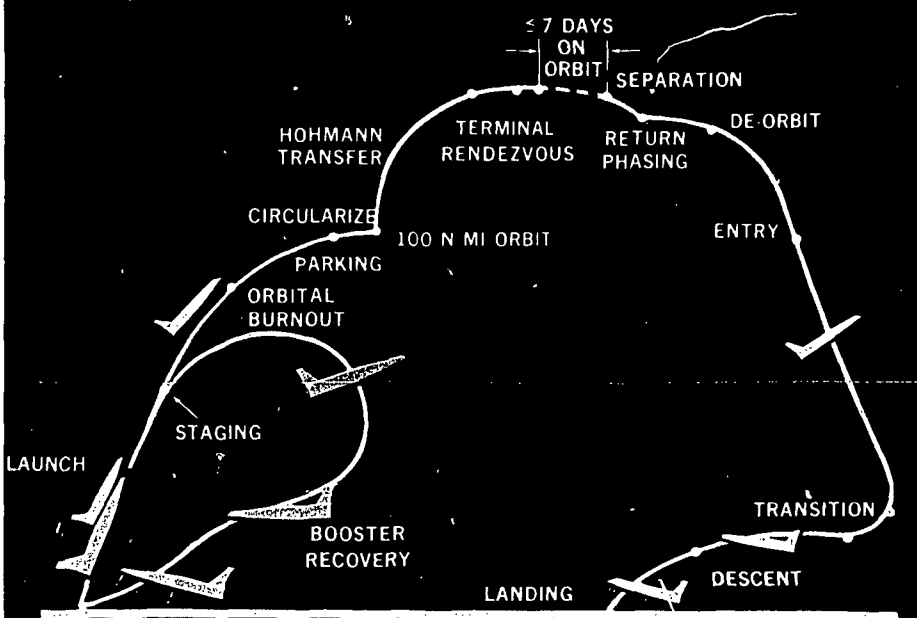

Fig. 1

Fig. 2

SPACE SHUTTLE TYPICAL MISSION PROFILE





"Scientific or applications tasks would be executed aboard the Shuttle by its passenger-scientists pretty much like scientific data are collected from an oceanographic research ship."

TWO STAGE SPACE SHUTTLE CONFIGURATIONS

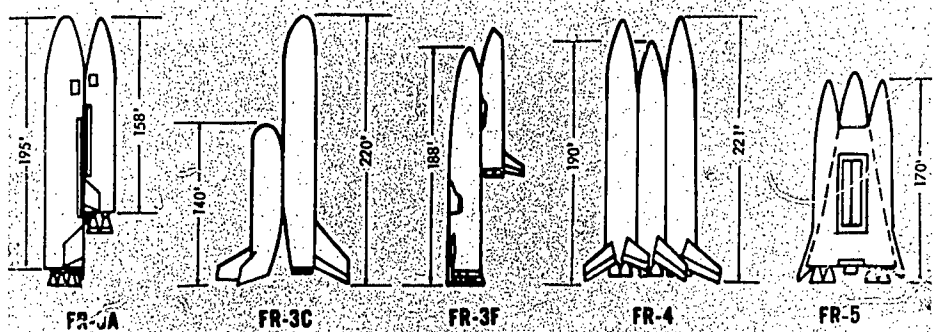

Fig. 3

A reusable Space Shuttle can be used for a wide variety of applications. For instance, it can carry quite a few passengers into orbit. The true astronauts, in our present sense of the word, would be confined to the cockpit—like the flight crew of an airliner. The passengers in the back could be scientists, engineers or technicians who need not have any higher medical qualifications than an airline passenger.

By placing tanks into the orbiter's cargo compartment, the Shuttle can also deliver propellants into orbit. Propellants will be needed for orbit-to-orbit transfer operations with the help of orbital "tugs," or to fuel nuclear "Nerva" type rockets for flights to the moon or the planets.

One of the most interesting uses of the Shuttle will undoubtedly be the "sortie" mission. The orbiter's cargo bay will be large enough to accom-

modate sizable instrument installations for astronomical and Earth observation. Many of these tasks can be completed within the orbiter's two-week life-support limit. Such scientific or applications tasks would then be executed aboard the Shuttle by its passenger-scientists pretty much like scientific data are collected from an oceanographic research ship. After two weeks, the orbiter returns both the scientists and their instrument installations to Earth and the instrumentation can be updated, modified or rebuilt. A few weeks or months later, the observers and their equipment can be taken aloft again for another orbital flight. In this operating mode it appears possible to make very substantial savings in space payload costs. These savings may indeed turn out to be the most important contribution of the Shuttle to the reduction of space flight costs. **A**

AN OVERVIEW OF THE SKYLAB, STATION AND SHUTTLE ROLES

Charles W. Mathews
Deputy Associate Administrator, Office of Manned Space Flight

We look upon both the Space Station and the Shuttle as the most significant elements in our approach to long-term, low-cost utilization of space.

Over the past ten years we have been able to maintain a fairly active pace of both manned and unmanned programs. Our unmanned programs have served to glean a mass of scientific data from space, as well as produced the first practical tools for putting space at the service of man; while our manned programs, in addition to expanding operational capabilities in successive steps, have culminated in one of the major achievements of this century — the journey to and landing of men on the moon. We have thus been able to vector our operational capabilities to areas of activity aimed at the needs of the future.

The unprecedented potential of the combined capabilities of the Shuttle and Station arises from the technological base and the experience developed from both manned and unmanned missions. In addition, before the Shuttle and Station concepts materialize, we shall also have the benefit of basic operational experience in late 1972, from the Skylab Program which uses much of the hardware and know-how developed in Apollo.

Pilot Functions of Skylab

Utilizing some of the hardware developed for the lunar exploration program, the Skylab will serve as an early experimental Space Station. It will be used for conducting scientific investigations in Earth orbit, to develop methods of assessing Earth's environment from space; and will also be used for gaining a detailed understanding of man's capability to live and work in space for increasing periods.

The principal scientific effort in this program will involve the use of a solar



"Economical space operations is the focal consideration around which the concepts of the Space Station and those of its logistics support vehicle, the Shuttle, have been evolving."

astronomy module for detailed studies of the sun, whose energy provides the driving force that controls our environment on Earth and throughout the solar system.

Another significant group of Skylab experiments shall center on applications, such as observations of Earth resources, meteorology, communications and material processing. This group of experiments will add to and complement the knowledge gained from ground-based research and automated space programs aimed at direct benefits to man.

A third cluster of activities planned for the Skylab will involve habitability, medical, behavioral and work-effectiveness experiments on missions of increasing duration, probably up to eight weeks. Biological studies are also planned on the effect of zero gravity on living organisms and the effect of the alteration of the basic rhythms, such as the sequence of day and night, which influence the processes of life.

The combined results of all these activities with the Skylab will give us vital scientific and engineering data we cannot acquire otherwise. These data will enable us to establish sound and economical bases for our subsequent phases of space operations and exploitation.

For Long Operational Spans

Until about a year ago, our plan was to utilize the spent Saturn IB second stage as the first Orbital Workshop after this stage had served its function as booster. The solar observatory part of the Skylab would then have been launched by another Saturn IB, and the two would have been docked together. However, the results of tests and Systems Engineering analyses indicated that flight hardware, launch facility requirements, and space flight

operations would be simplified considerably by launching the Workshop with a single Saturn V completely outfitted on Earth. Thus, by combining the delivery capabilities of the Saturn V and the modest accommodations provided by the Skylab, for scientists and experiments, we shall be able to achieve useful operational spans measurable in weeks and months.

In view of the considerably longer-life utility and functional flexibility needed for economical Space Station operation, however, the all-up approach to be used for the Skylab was considered impractical for the Station. Instead, we decided to plan the development of the Station and that of the experiments in a coordinated manner, yet separately, for two reasons: to simplify overall management; and to provide for the evolutionary changes of experiment packages toward new requirements, by using a modular approach.

Economy is Focal Consideration

Actually, economical space operations is the focal consideration around which the concepts of the Space Station and those of its logistics support vehicle, the Shuttle (discussed in adjacent articles), have been evolving. And the economy we are planning to achieve is based on long-term to permanent use, with the avoidance of systems that are dead-ended in purpose. Or, in other words, the intent behind the Space Station and Shuttle system is to make space more accessible to investigators having meaningful activities to conduct.

From the long-term use and flexibility aspects then, the modular concept is the basis for the block-by-block evolution of the Space Station itself, as well as of the associated experi-

ments. The experiment modules shall house new laboratory and observatory facilities as they become available, and be delivered to the Station (or returned to Earth as needed) by Shuttle. We are currently studying, under contract, various versions of experiment modules, including some intended to be attached externally to the Station, and others that will orbit at a distance from the Station, as self-supporting systems.

Catalog of Experiments Evolving

We cannot foresee, of course, what we may exactly need in terms of investigations over the next ten or fifteen years, but starting as early as in 1968 we have been working to develop a so-called catalog of candidate experiments grouped into functional areas of activity. Since then, successive studies by contractors have served to define in more detail the scope and sequence of these experiments. These efforts culminated in a Space Station Utilization Symposium held in September 1970 at NASA's Ames Research Center, Moffett Field, California. User panels by discipline areas and of international memberships — from industry, government and universities — will now advise NASA on the optimum use of the Space Station, and make recommendations to establish detail requirements and priorities.

International Participation

We are greatly interested in promoting international participation in the Space Station and Shuttle programs, and have already held a number of briefing conferences to this end, both here and abroad. We held a Space Station Overview meeting in Paris, early in June, with the participation of over 250 European Space Research Organization (ESRO) members. We



"From aspects of long-term use and flexibility, the modular concept is the basis for the block-by-block evolution of the Space Station itself, as well as of the associated experiments."

also had a meeting with the European Launcher Development Organization (ELDO) in July, and discussed the possibilities of ELDO's participation in the development of an interorbit transfer vehicle as part of the Space Station and Shuttle system. In addition, at the invitation of the European Space Conference (ESC)* a group of NASA and

**Member countries of ESC are Australia, Belgium, Denmark, the Federal Republic of Germany, France, Italy, Netherlands, Spain, Sweden, Switzerland and the U.K.*

industry officials headed by Dr. Homer E. Newell, Associate Administrator of NASA, briefed European space representatives, in Bonn, on U.S. space transportation plans, including the reusable Space Shuttle. Lastly, we participated in the Fourth Eurospace Industrial conference held in Venice, Italy, in late September, where informative discussions were held between U.S. industry officials and their European counterparts on respective plans and capabilities. These continuing discussions are serving to establish the foundations of our cooperative efforts on projected programs.

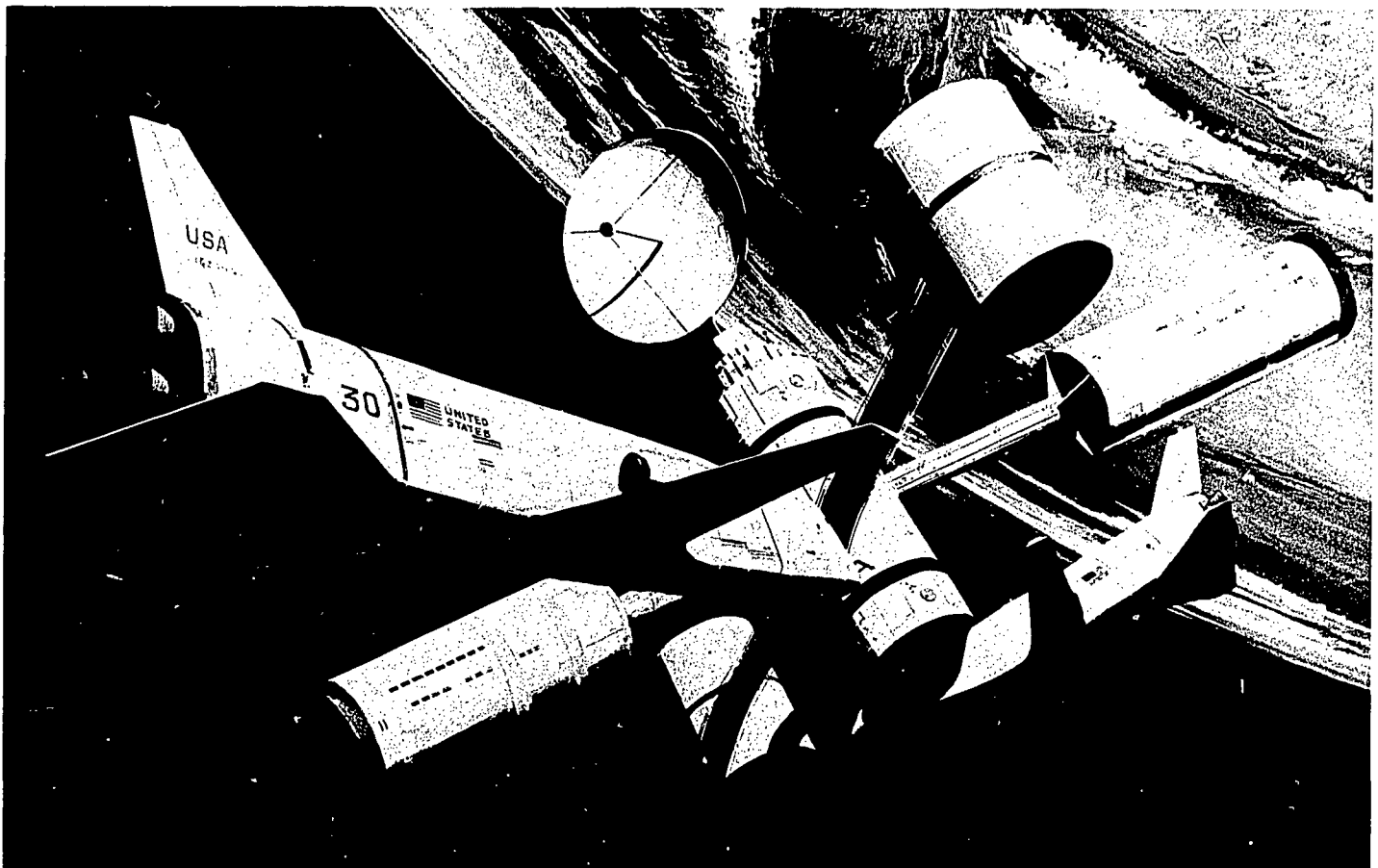

Docking of Shuttle with Station, conceptualized by North American Rockwell's Space Div.

Versatility of Shuttle

An aspect I would like to stress, as related to the Shuttle, is that its function should not be viewed only as logistic support. We envision the Shuttle as a versatile work-horse capable of replacing a large variety of launch vehicles between the Scout and the Saturn V — not only for U.S. users, but for other countries as well. In addition to serving as a regular Earth-to-Space Station ferry-vehicle, to transport crews and supplies, the

Shuttle would also be used to return processed experiments to Earth, to replace or repair equipment in orbit, and to function as a rescue vehicle. Automated satellites have proven their practical usefulness to man in many ways. But they have been vulnerable to modes of automated deployment, and been limited in life spans from considerations of reliability and by the finite quantities of consumables on board. The use of a Shuttle would make it possible to control the deployment of satellites at close range and

assure their operation before leaving them in orbit unattended; it would also enable us to effect in-orbit repairs, to resupply consumables, or to retrieve payloads for shop-repair on Earth. But how far up or down we may go in delineating the Shuttle's capabilities may depend on cost considerations, which in turn depend on the extent of projected usage. The coordination of user needs, both domestic and international, is therefore a vital step at this stage of program planning.

The design concept of the Shuttle,

like that of the Station, centers on low cost achieved through a large number of reuses of the same vehicle with a minimum of refurbishment. The Shuttle is a combination of a rocket-propelled space vehicle and airplane, and as such it poses unique ground- and flight-test requirements, but the development costs must be kept as low as possible. We are applying the concept of early testing of critical components to perform design verification tests on such critical features as light-weight structures and heat shields. These will be large or full-scale build-ups resulting from the preliminary designs which will be accomplished by industry in the Definition Contract Phase. Also, during the 11-month Definition Phase there will be heavy emphasis on wind-tunnel testing of the various configurations. Some wind-tunnel testing has been done over the past year on possible configurations for the Shuttle. As the point designs which will be accomplished during the Definition Phase are sharpened, considerable tunnel testing will be needed to identify the expected aerodynamics, stability and control, and thermal characteristics.

Ground and Flight Tests

Our engineering ground-test program will be a combination of techniques presently used for manned space vehicles and large high-performance aircraft. But the large size of the Shuttle will limit environmental testing mostly to the module level.

We are presently in favor of using, for test purposes, vehicles that can later be refurbished for full operational use. This would be similar to the approach used for the C5A and the 747.

Because the initial number of Shuttle vehicles produced will be small, probably less than five, the



"We are greatly interested in promoting international participation in the Space Station and Shuttle programs."

vehicles allotted to flight test will represent a significant portion of the "fleet" cost. Our present plans are also to implement a flight-test program in stages of progressive difficulty, which would parallel to some extent the ground tests. In addition to conducting suborbital flight-tests, as in the case of past space vehicles, in flight testing the Shuttle we shall also use an aircraft development approach — with modifications and corrections for malfunctions being made following each test phase.

The operational flight regime of the Shuttle will, or course, be extensive and rigorous. But the testing experience from the Mercury, Gemini and Apollo spacecraft added to our findings from aircraft such as the B-58, XB-70, X-15, and the SR-71 will provide a valuable background. If we were to look further down the line, flight research data from the Shuttle would contribute to the development of commercial transports beyond the

forthcoming generation of Supersonic Transports. This would be the generation of surface-to-surface sub-orbital transports foreseen operating about the turn of this century.

Expandable System for the Future

In considering long-range and economical space capabilities for the future, the Space Shuttle and Space Station should be viewed as one system with functionally interrelated elements. The overall concept is in essence a block-by-block long-range plan amenable to unfolding at various rates — based on our progress in acquiring new knowledge and funding.

The Space Shuttle represents our first space vehicle concept featuring reusability; and the Space Station features commonality to the extent that it can be used in many ways: initially in low Earth orbit (240 to 270 miles), later in synchronous orbit (about 28,000 miles), or in lunar orbit, and ultimately in interplanetary space.

Our studies indicate that as resources become available in later years, the benefits from these concepts might be expanded in Earth-orbit and extended to the surface of the Moon by the introduction of two additional systems: the Nuclear Shuttle and the Space Tug. The Nuclear Shuttle propelled by the NERVA nuclear rocket, is envisioned as a reusable vehicle used between Earth-orbit and lunar orbit, or between low Earth-orbit and synchronous orbit. The Space Tug, a complementary vehicle propelled by chemical rocket, would be used to move passengers and cargo between lunar orbit and the Moon's surface. This vehicle would also exhibit commonality since it might be utilized both as a transfer vehicle in Earth-orbit, and to move small payloads from low Earth-orbit to synchronous orbit or lunar orbit. Lastly, it appears that in the exploration of the solar



"If decisions are made now to proceed toward these programs, both nationally and internationally, we shall have the distinct and joint advantage, this time, of a head-start on the effective utilization of space for the benefit of all mankind."

system also we might be able to use and adapt systems and techniques developed within the framework of commonality and reusability.

To Serve Multiple Interests

As I implied earlier, low-cost transportation to and from space is the reason for having the Space Station and Shuttle system. The capabilities of such a system would open space to a broad spectrum of public, private and international interests.

From impressions gathered from our international meetings on future space efforts it becomes quite clear that the possibility of cheap space-transportation constitutes beneficial prospects from numerous national vantage points. And the question that seems to concern a good number of our overseas colleagues, at this point, is not whether they should participate, but how they might contribute to the

augmentation of the projected Station and Shuttle system capabilities. Some of the machinery for coordinating joint efforts is already established and operating*; we look forward, of course, to seeing our working relationships expand further.

Role of NASA Centers

Speaking in broad terms, the participation of international agencies in these major programs would be somewhat in the manner of our NASA Research Centers. These Centers manage the implementation of specific portions of programs assigned to them by NASA Headquarters, and phase into industry which provides the technical resources and brings needed hardware into being.

In the current Phase B definition of the Shuttle Program, for example, contractors are expected to implement efforts to cover all aspects of the Shuttle: analyses and design verification of evolving operational concepts, technical studies, definition of further effort to move into subsequent activities, etc. Our in-house activities are primarily to support and complement — not to replace — the work performed by contractors.

It took nearly a full decade of broad-scale effort on an unprecedented scale to translate a national commitment into manned lunar landings. It will require a similar time span to progress from our present experimental era in space, into the stage of operational maturity. Therefore, if decisions are made now to proceed toward these programs, both nationally and internationally, we shall have the distinct and joint advantage, this time, of a head-start on the effective utilization of space for the benefit of all mankind. **A**

**See article starting on page 81 on Cooperative International Programs.*

SPACE SHUTTLE REQUIREMENTS, PROGRAM PLANS AND PROGRESS

Dale D. Myers
Associate Administrator for Manned Space Flight

A realistic way of looking at the major challenges of the Seventies would be to visualize them as an organization chart or hierarchy of related problems and priorities.

Our priorities at NASA extend from the advancement of aerospace sciences, technology and applications aimed at the betterment of man, to the exploration of space. And the underlying requirement for all these things is that they be done at least cost.

During the last decade space exploration became a catalyst for revitalizing technology, and acquired a place in the American way of life; in this decade space activity must increasingly pay its way in order to acquire support. This is another way of saying that the benefits of space must become available at down-to-earth costs.

An implication of this requirement is that our future space activities will have to mature — from the heretofore experimental mode, using expendable systems — into an operational mode utilizing reusable systems. This concept of reusability, as projected for the space operations of the late Seventies and beyond, is incorporated in an integrated space system which would include a Space Shuttle and an orbiting Space Station. We would thus combine a reusable transport vehicle with a permanent laboratory in space for scientific and technological work and Earth-resource surveys.

Space Shuttle System

As visualized now, the Space Shuttle would consist of a completely reusable rocket-powered, two element vehicle composed of an orbiter and a booster. The Shuttle's operational mode would be a vertical launch whereby the booster would accelerate the orbital vehicle to the outer fringe of the Earth's atmosphere where separation of the two would occur. Upon

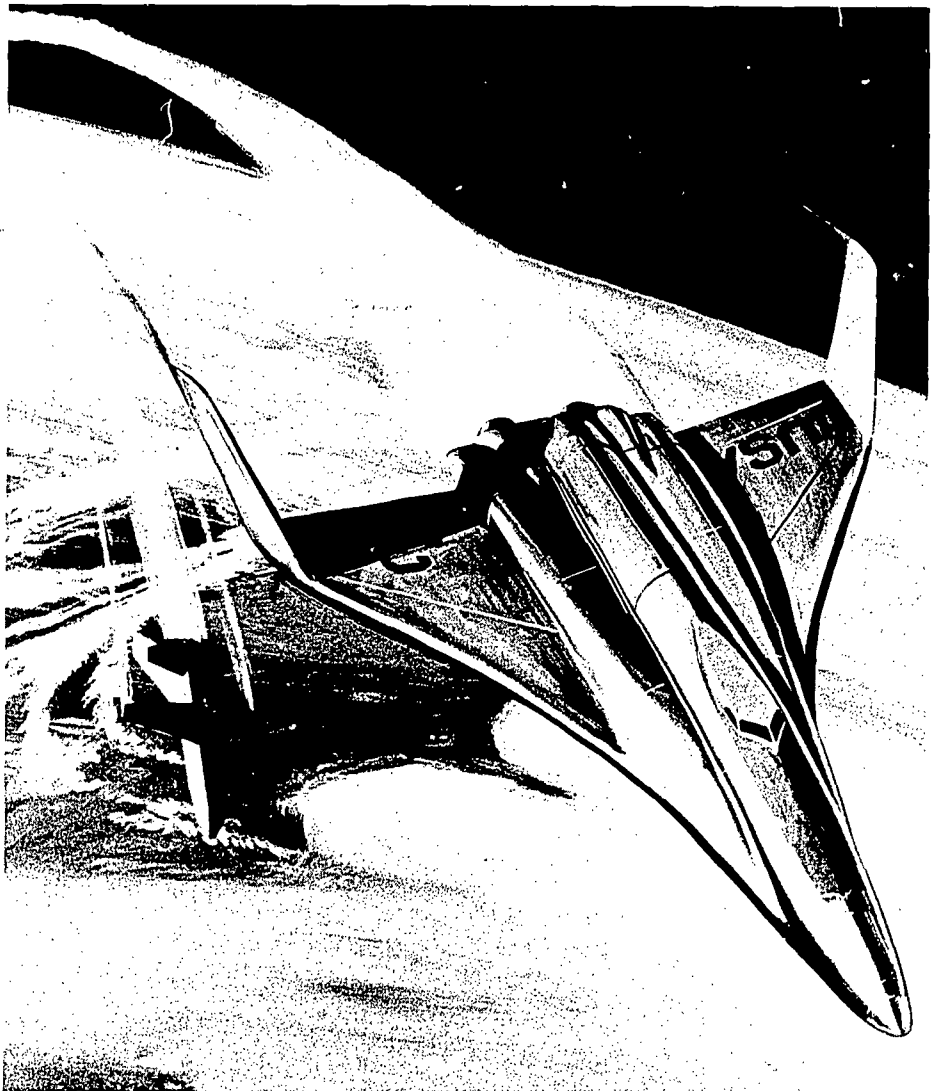

Space Shuttle orbiter configuration, by North American Rockwell's Space Division, aimed at reentering Earth's atmosphere at low angles of attack in order to achieve relatively high cross-range capability.

reentry and deceleration, the booster, powered by jet engines, would cruise to a site for a conventional airplane-type landing. Meanwhile, the orbiter element would proceed to orbit, powered by its own rocket engines, to deliver its payload and perform its assigned missions. After reentry, the orbiter would land with its return cargo, also under jet power. After a checkout period of about two weeks, and minor refurbishment and refueling, both the orbiter and booster would be ready for another mission. Launch operations would be simplified by system-diagnostic instrumentation on-board, so that only vehicle erection, propellant loading and final boarding of payload and passengers would be necessary. Pre-launch checkout would be carried out on-board by the pilots.

Product of Cooperative Studies

The Space Shuttle is a product of cooperative studies conducted by both the Air Force and NASA over a number of years. The Space Task Group Report "The Post Apollo Space Program - Directions for the Future", submitted to the President in September 1969, indicated the need for a new space transportation system that would meet the requirements of both the DOD and NASA. Our studies with the DOD - based on recent advances in rocket engines, thermal protection and structural concepts - led to the conclusion that a Shuttle system suitable for the needs of both agencies should be developed.

Since the Shuttle would be essentially a transporter and cargo vehicle, its utility would not be restricted to a single program or a single agency. Rather, we expect that at the very earliest opportunity both NASA and DOD space programs would benefit from this development. To this end, extensive cooperation between NASA

and DOD in analysis, design and subsequent development will be maintained. We believe that eventually commercial uses will also be found for the Shuttle.

The universal applicability of the Shuttle is expected to provide opportunities to expand and improve international cooperation in space. In October 1969, NASA invited international participation in a Space Shuttle conference held in Washington, D.C., and considerable interest in the Space Shuttle was expressed then and has been since, in conferences held in Europe during this past Summer and Fall.

Operational Characteristics

The Space Shuttle is expected to weigh between 3 and 4 million pounds at launch, and will be propelled by liquid-oxygen and liquid-hydrogen engines. These rocket engines, to be used both for the booster and orbiter, are being designed to generate thrust of about 400,000 pounds each. The booster will be powered by about 10 of these engines, and the orbiter by 2 or 3. Our choice of these propellants is based on our experience in Apollo, particularly on our ability to handle them safely and relatively easily on the ground during loading and transfer. We feel it will be possible to load the Shuttle directly from tank trucks at the launch pad, and thus greatly reduce both facility and handling costs. Another great advantage to these propellants is that they do not produce toxic chemicals to pollute the atmosphere.

With a payload compartment 60 feet long and 15 feet in diameter, the orbiter would accommodate varying combinations of personnel and cargo, in a pressurized environment similar to that of current commercial jetliners. An important objective of the Shuttle program is to provide a very benign

environment — both in terms of flight stress and pressure — for passengers and payloads, from launch to landing.

The Shuttle would provide round-trip transportation from Earth to low Earth-orbits. Its operational altitude would range from about 100 to 800 nautical miles, with most missions taking place in the 100 to 300 nautical mile range. The Shuttle would also be capable of operating as a rescue vehicle.

As space operations advance, the traffic carried by the Space Shuttle will include propellants. Supply depots which may be established near the Space Station or in other suitable orbits, may provide facilities for fueling and reprovioning space vehicles for travel out to more distant destinations.

An early cost study, based on the NASA traffic model of 30 flights per year, was made to determine the economics of the Shuttle based on the use of present-day launch vehicle systems such as the Atlas, Titan, Saturn series or their derivatives for comparable payloads. This analysis indicated that the Space Shuttle development costs would be recovered through its economy of operation after about 5½ to 6 years of utilization. Air Force usage plus any increased flight density could significantly shorten this break-even period. Even a greater potential in reduction of the cost of payloads is anticipated.

Economic Considerations

The total number of Shuttles that will eventually be built is not known at present; however, for the purpose of computing systems costs we considered a fleet of four to six Shuttle systems supporting the baseline traffic model. Our design objective is to make each Shuttle capable of 100 flights without major refurbishment. Therefore, with several Shuttles making 100



"Our design objective is to make each Shuttle capable of 100 flights without major refurbishment. Therefore, with several Shuttles making 100 flights each we would accomplish a total number of flights substantially greater than required to reach the break-even point (about 100 to 150 total flights) in competition with expendable systems."

flights each we would accomplish a total number of flights substantially greater than required to reach the break-even point (about 100 to 150 total flights) in competition with expendable systems.

Of the several classes of Space Shuttles studied, the fully-reusable class has been determined to be the most economical configuration for achieving a low-cost transportation system with a high degree of operational flexibility.

The critical design and development areas for the Shuttle have been subjected to progressively more penetrating reviews, and these have produced candidate configuration concepts resulting in definition of desired Shuttle systems characteristics. In addition, we now have confidence that the technology and engineering required to move into the next phase of activity is

either available, or well defined and readily achievable.

Chronology of Contracts

November 1, 1969 — Convair Division of General Dynamics, Lockheed, McDonnell Douglas, and North American Rockwell, each completed a \$450,000 Phase A study portion of the Shuttle Program.

February 18, 1970 — NASA issued requests for proposals for preliminary definition and planning studies of the Shuttle's main propulsion system: liquid-hydrogen, liquid-oxygen fueled engines for launch, orbital insertion and flight operations, and reentry. RFP recipients were: Aerojet General, Bell Aerospace Systems, Marquardt, North American Rockwell, TRW, and United Aircraft's Pratt and Whitney Aircraft Division. Subsequently the three companies submitting replies to



"In this decade space activity must increasingly pay its way in order to acquire public support."

the RFP were selected for these Phase B engine definition studies: Rocketdyne Division of North American Rockwell, Aerojet General and Pratt and Whitney.

February 20, 1970 – RFPs issued for preliminary definition and planning studies for the Space Shuttle System to Boeing, Chrysler, General Dynamics, Grumman, Lockheed, Martin-Marietta, McDonnell Douglas, and North American Rockwell.

May 12, 1970 – NASA selected McDonnell Douglas and North American Rockwell's Space Division for final negotiations of parallel 11-month contracts – valued at about \$8 million each – for definition and preliminary design studies of the Shuttle. NASA's Marshall Space Flight Center will manage the McDonnell Douglas work, and the Manned Spacecraft Center will manage the North American Rockwell contract. Both are Phase B contracts.

July 15, 1970 – NASA selected Grumman Aerospace Corp., Lockheed Aircraft Corp., and Chrysler Corp., for 11-month Phase A (feasibility) contracts to study several alternate Shuttle concepts – with Boeing Co. as major subcontractor to Grumman. These studies are aimed at rigorously reexamining the feasibility of Shuttle concepts that might be competitive – technically and economically – with the concept of the two-stage fully-reusable system.

The Grumman/Boeing fixed-price contract, with an estimated value of \$4 million, will be managed by NASA's Manned Spacecraft Center. This contract involves the study of three different concepts:

(1) A stage-and-a-half Shuttle consisting of a single reusable manned spacecraft with an on-board propulsion system and droppable tanks to provide supplementary propellants.

(2) A reusable orbiter with expendable booster. This is envisioned as

a second-stage orbiting Shuttle launched on an existing expendable booster, or on a new minimum-cost first-stage-liquid or solid-propellant booster.

(3) A reusable first stage using existing J-2S engine technology, and solid-propellant auxiliary boosters with a reusable second-stage orbital Shuttle also powered by J-2S engines. The J-2S is an advanced version of the J-2 hydrogen-oxygen engines successfully used on the second and third stages of the Saturn 5 launch vehicle.

The Lockheed study, to be managed by NASA's Marshall Space Flight Center, will define an alternate stage-and-a-half Shuttle system including both low and high cross-range designs. Estimated value of the Lockheed fixed-price contract is \$1 million. In a related Phase A (feasibility) effort, the Chrysler Corp. will study another concept—a reusable vehicle that can place a payload into Earth-orbit with a single stage. This fixed-price contract, with an estimated value of \$750,000, will also be managed by the Marshall Space Flight Center. Correlation of results from all these studies will help ascertain that the Shuttle concept finally selected for development will represent the most cost-effective approach to future space transportation.

August 4, 1970 — NASA awarded a \$1,366,400 contract to General Electric Company, Aircraft Engine Group, to build fuel systems needed for studying the operation of turbojet engines using liquid methane and liquid hydrogen fuels. This contract will be supervised by the Lewis Research Center — NASA's prime Center for R&D related to aircraft and spacecraft propulsion. Lewis will use the GE systems with present turbojet engines to study the fuel-system dynamics associated with the use of liquid methane as a possible fuel for future generations of supersonic aircraft and liquid hydrogen for the Space Shuttle.



"Future space activities will have to mature — from the heretofore experimental mode, using expendable systems — into an operational mode utilizing reusable systems."

Space Shuttle orbiter concept, by North American Rockwell, represents configuration intended for reentry at steep angles of attack in order to shorten the duration of high heat loading.

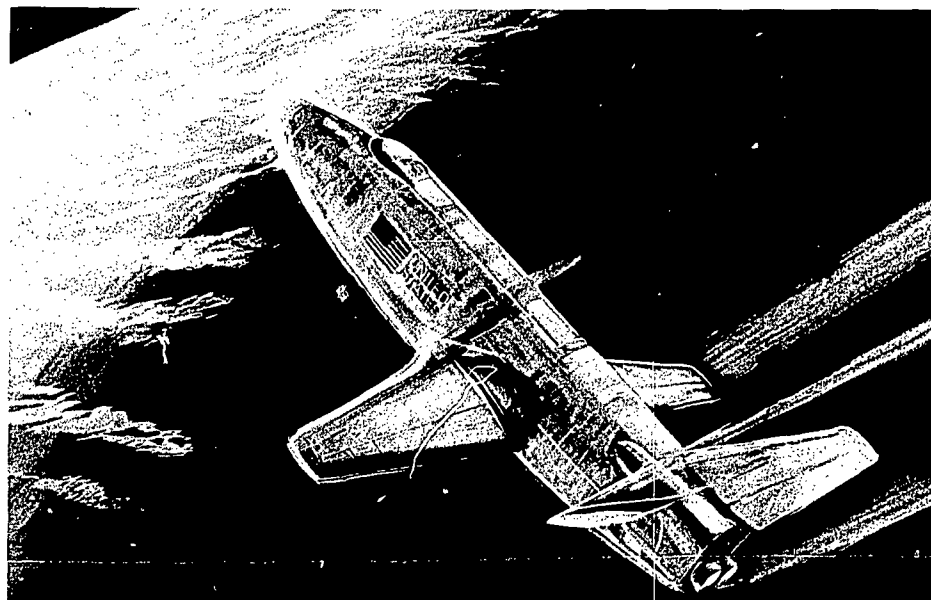

Phase B Objective

This Phase has as its basic objective the derivation of detailed information which is prerequisite for follow-on phases of design and development. These Phase B studies will be focused on specific point designs and supporting technology for both high and low cross-range maneuverability configurations. The systems characteristics to be used as the baseline for the Phase B study are listed below.

1. Fully reusable vehicle — with flyback.
2. Vertical take-off — horizontal landing.
3. Gross lift-off weight 3.5 million pounds.
4. Payload compartment size 15' diameter by 60' length.
5. Maximum attainable payload.
6. 400,000 pound thrust bell-type engines.
7. Vehicle life of 100 missions

8. Intact abort.
9. Two-man crew.
10. Air breathing engines will burn hydrogen fuel.
11. Shuttle orbiter self-sustaining for 7 days.
12. Shirt-sleeve environment for crew and passengers.

Phase B engine contractors will provide preliminary designs for high and low cross-range, provide specifications, and deliver selected configurations for wind tunnel testing. Also to be accomplished during the Phase B period are demonstrations of critical structural design and fabrication techniques.

The Shuttle effort has progressed to the point where the current Phase B definition studies are the next logical step in providing a basis for continued refinement and definition of competing designs to the point of preparedness necessary for initiation of development.



"The Space Shuttle concept is a product of cooperative studies conducted by both the Air Force and NASA over the years."

PHASE B SHUTTLE MANAGEMENT PLAN

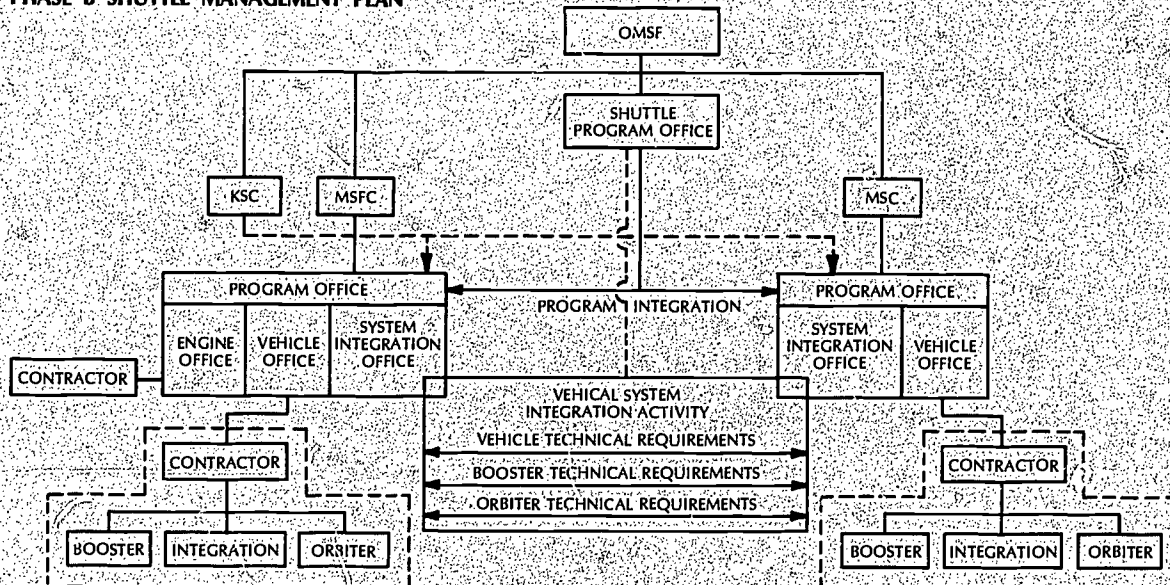

Shuttle Management Plan

NASA's Office of Manned Space Flight will manage the Space Shuttle Program, with initial contractual responsibility for one total systems study at the Manned Spacecraft Center and one at the Marshall Space Flight Center. For follow-on phases, however, MSC will be responsible for the orbiter and MSFC for the booster work. During the Phase B study effort each Center will participate in the technical direction of the part of the total system for which the Center will assume ultimate responsibility. This plan essentially provides for technical direction of the booster elements by MSFC, regardless of which Center handles the total systems contract. Similarly, MSC will be responsible for the technical direction of the orbiter elements of the total systems contracts. As reflected in the accompanying chart, program offices, one located at MSFC and the other at MSC will each contain an integration group that will be composed in part of personnel from the other Center. The purpose of this program office structure is to ensure the necessary coordination and cross-fertilization. **A**



"An important objective of the Shuttle program is to provide a very benign environment — both in terms of flight stress and pressure — for passengers and payloads, from launch to landing."

SPACE STATION OBJECTIVES, OPERATION AND APPLICATIONS

Dale D. Myers
Associate Administrator for Manned Space Flight

Space Station Objectives

The Space Station will be a centralized facility in Earth orbit supporting a wide variety of space activities. It will be similar to a highly flexible multi-disciplinary research, development, and operations center on Earth. The Space Station will utilize and exploit the unique features provided by its location in low Earth-orbit —

weightlessness, unlimited vacuum, wide-scale Earth viewing, and unobstructed celestial viewing — with the direct presence of skilled scientists and engineers to pursue a wide variety of research and applications activities. Like its Earth-based counterpart, the Space Station will be configured for support and conduct of activities in many identified areas, and will have

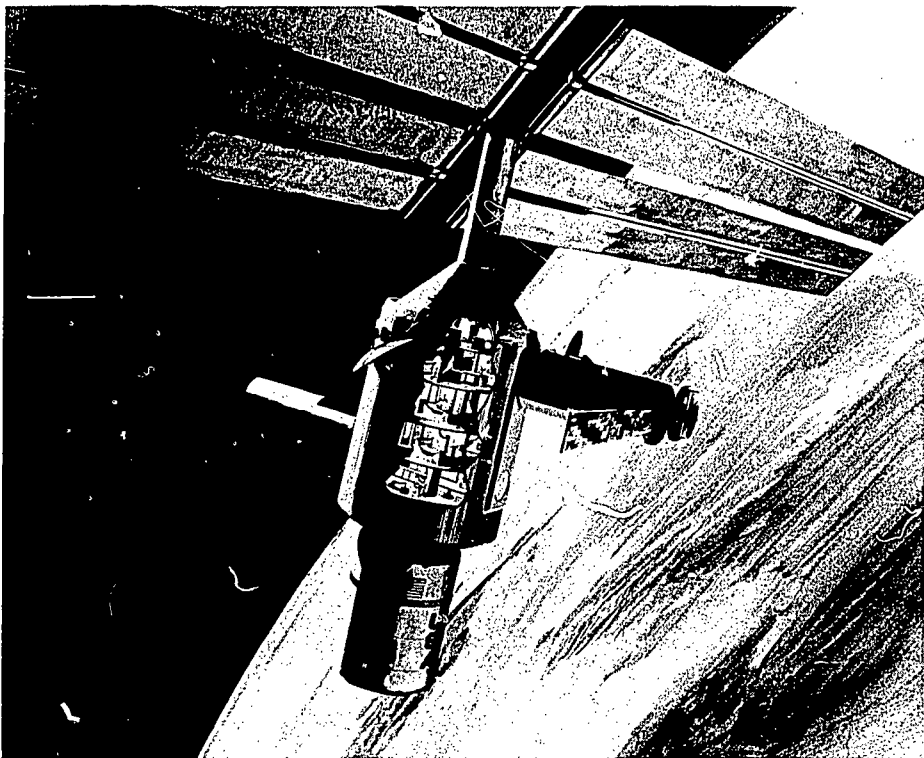

Conceptual presentation of multi-deck Space Station, by North American Rockwell, shows Earth Surveys Module mounted on the side of the Station oriented to the Earth (at right).

the flexibility to support others which may not be defined in detail at present.

The activity categories and examples listed below provide a basis for establishing the nature of the Space Station Program.

Technology Forcing Function — Intrinsic in the development, use, growth, and continual updating of a major space facility and its equipment.

Sciences — The combined environment, facilities and crew will provide excellent research opportunities in many disciplines including astronomy, life sciences, physics and chemistry.

Exploration — Essential data acquisition, equipment development and qualification, and operational concept demonstration and training for future manned missions to the Moon and planets.

Public Services — Global surveys in Earth resources and meteorological disciplines, primarily for the development of better equipment and techniques, but also for user-oriented data collection.

Foreign Relations — A focal point for productive international cooperation and joint ventures, including the use of foreign nationals as members of the on-board technical team.

Private Sector Support — Unique materials and manufacturing research and, possibly, production services exploiting the zero gravity and hard vacuum environment — for example, growth of large crystals, formulation of composites and precision casting.

National Defense — Spacecraft equipment and operations development which will have application to future military missions and systems.

Orbital Operations — A servicing and maintenance platform for both unmanned and manned spacecraft in Earth orbit and in transit to and from the Moon and deep space.

An operational Space Shuttle (discussed in some detail in adjacent arti-

cles) would make the economical logistic servicing of the Space Station possible.

The initial Space Station module would accommodate as many as 12 persons, most of them to be engaged in useful orbital activities, rather than merely in "housekeeping" tasks. The Station would have an internal volume of over 30,000 cubic feet, a 33-foot diameter, and a length of about 40 feet. It would weigh 60 tons or more.

Orbital research activities will ultimately be staffed with specialists with a minimum of astronaut-type training or physical conditioning. Therefore, particular attention will be paid to assuring comfortable, attractive and effective working and living conditions. The provisions may include individual quarters, kitchen and dining facilities, recreation areas, showers and greatly improved toilet facilities. Housekeeping functions will be highly automated to free the crew as much as possible for more productive work.

Operational Mode

Although the Station will be designed for operation in a zero-gravity mode, it will also be able to carry out an engineering and operational assessment of artificial gravity in the early weeks of its mission. The Station is expected to be operated in circular orbits inclined 55°, and at approximately 270 nautical miles altitude, in order to accommodate the wide variety of experiments identified so far, including Earth-viewing applications. Circular orbits from 240 to 270 nautical miles would require more propellant for remaining in orbit, and higher altitudes would provide less atmospheric protection from natural radiation.

Before the Space Station becomes a reality, however, the Skylab missions (formerly Apollo Applications Pro-

gram) projected for the latter part of 1972 will provide a wealth of design and operational data for the Station. Assuming successful accomplishment of the Skylab missions, using the Saturn V as a launch vehicle, these missions will develop data on the following aspects:

- Physiological effects of zero gravity on the crew for periods up to 56 days.

- Effectiveness of task performance in station-type activity.

- Habitability of the orbital workshop.

- In-flight qualification and demonstration of several important new components, including large solar arrays, control-moment gyros and molecular sieves.

- General experience in logistic and orbital operations, including major in-flight experiments. Additional data to be derived from the Skylab will be identified as the Space Station definition effort progresses.

Larger Space Base

Provided it has been proven economically feasible and desirable, the Space Station could eventually be developed into a large Space Base in low Earth-orbit. The Space Base would be constructed by clustering Space Station and other specialized modules. The Base would provide a large space laboratory of common equipment and modules where non-astronaut scientific personnel would be able to conduct a variety of scientific experiments. Initially, the Base would accommodate approximately 50 persons, including the operations team to perform command, control, service, and maintenance functions. Growth to a 100-man capacity would be possible.

In order to incorporate the extent of flexibility toward future growth that may be required for a national research and operations center, the

Space Base would be modular in construction, so that it could be re-modeled or expanded in orbit, using the logistic capabilities of the Space Shuttle. The Space Base would be designed with large safety factors and performance margins in keeping with its semi-permanent character.

Research and Applications

The total spectrum of future activities to be conducted in the Space Station and Space Base cannot be foreseen at this time. Many good proposals and concepts for research and applications are already in development. This situation is analogous to the one that exists whenever plans are being formulated for a major new Earth-based laboratory. In fact, history shows that unexpected uses, discoveries and payoffs often outweigh the planned payoffs on the frontiers of science and technology. Table 1 summarizes some of the most promising fields of research and experiments we can foresee at present.

Station Effort Management

The Deputy Associate Administrator for Manned Space Flight is responsible for the agency-wide supervision and integration of the total Space Station effort.

An agency-wide steering group including the directors of participating Centers was established to provide periodic review of the Space Station Program. This group provides guidance to the Deputy Associate Administrator of Manned Space Flight in the conduct of the overall program.

A Task Force with the Deputy Administrator of Manned Space Flight as Acting Director is organized within the Office of Manned Space Flight. This Task Force has the responsibility for the overall management of the program definition effort, for the

preparation of the overall in-house report evaluating the results of definition studies, and the preparation of the plan for design and development. In carrying out these responsibilities, the Task Force is assisted by personnel of NASA Centers. The Manned Spacecraft Center and the Marshall Space Flight Center have established in-house task teams for this specific activity, and have assigned personnel needed to manage the portions of effort assigned to them.

For the definition (Phase B) effort, two parallel contracted studies are being conducted; one is managed by the Manned Spacecraft Center, and the other by the Marshall Space Flight Center. Other NASA Field Center responsibilities include the management of contracted supporting studies, and performance of in-house studies and support to Source Evaluation Boards, Steering Groups, Technical Panels, and the evaluations leading to the Design and Development/Operations phases.

Monitoring Definition Phase

A Space Station Technology Management Team, directed by the Office of Advanced Research and Technology and composed of representatives of all Centers and Headquarters program offices, has the responsibility to focus research and technology to support Space Station developments.

Technical monitoring of the Definition Phase activities is accomplished by a Technical Review Group, composed of senior personnel from Headquarters, the Centers, and other appropriate activities. This Group meets at six-week intervals to review progress in all aspects of the Definition Phase, and to make recommendations regarding the future. At the end of each three-month period, prime contractors make a presentation to the

NASA Administrator and the Steering Group on the status of the Definition effort.

Other elements of NASA will be called upon for participation in the selection of experiments and in areas over which they have technical or program authority. Broad areas of responsibilities for experiments are as follows:

- Office of Space Science and Applications for science and applications.
- Office of Advanced Research and Technology for technology.
- Office of Manned Space Flight for engineering, space medicine and mission operations.

These Offices will exercise technical and program management authority for the definition of experiments. The Office of Space Science and Applications and the Office of Advanced Research and Technology will continue to maintain technical and scientific responsibility during the development of the experiments; these will be under the direction of the Office of Manned Space Flight, as an integral part of the Space Station development program.

Program Status

NASA is currently involved in the Phase B definition of a Space Station Program. The overall objective of this effort is to obtain the technical and managerial information required so that a choice of a single approach to a Space Station can be made from the alternate approaches available.

Major contracted support to the definition effort consists of two parallel, \$2.9 million studies with industry initiated with Fiscal Year 1969 funding. One of these studies, conducted by a team headed by McDonnell Douglas, has been monitored by the Marshall Space Flight Center;

TABLE 1
SUMMARY OF CANDIDATE EXPERIMENTS AND PAYLOADS
FOR THE SPACE STATION

DISCIPLINE	EXPERIMENT GROUP	DESCRIPTION
ASTRONOMY	Grazing incidence X-ray telescope Stellar astronomy module Solar astronomy module UV stellar survey High-energy stellar survey	Advanced research in astronomy to understand origin and evolution of the universe by observing and interpreting the basic physical processes in the solar system, stars and galaxies.
SPACE PHYSICS	Cosmic ray physics laboratory Ionospheric plasma investigations	These experiments will increase knowledge of the fundamental laws and principles of physics as manifested by physical phenomena.
AEROSPACE MEDICINE	Biomedical and behavioral research Man/System integration Life support and protective systems	Research to understand man's reaction to the space environment and to determine the role and function of man in long duration space flight.
ADVANCED TECHNOLOGY	Contamination and exposure Large space structures development Fluid physics in microgravity Sensor development and calibration Advanced subsystem development	A group of experiments intended to develop the design data for advanced long duration space flights, and contribute to the technology required to obtain maximum benefits from space programs.
SPACE BIOLOGY	Small vertebrates Plant specimens	Research on the effects of gravity and time on plants and vertebrates.
EARTH SURVEYS	Earth resources and meteorology Meteorology subsatellite	Experiments intended to provide insight into the beneficial uses of near-Earth space with emphasis on weather prediction and resources prospecting techniques.
INDUSTRIAL ENGINEERING AND APPLICATION	Materials science and processing MSF engineering and operations	Research will provide fundamental knowledge on the effect of gravity on physical processes leading to advances in industrial processes. Engineering experiments will advance knowledge of space flight.

"The Space Station will utilize and exploit the unique features provided by its location in low Earth-orbit — weightlessness, unlimited vacuum, wide-scale Earth viewing, and unobstructed celestial observation — with the direct presence of skilled scientists and engineers to pursue a wide variety of research and applications activities."

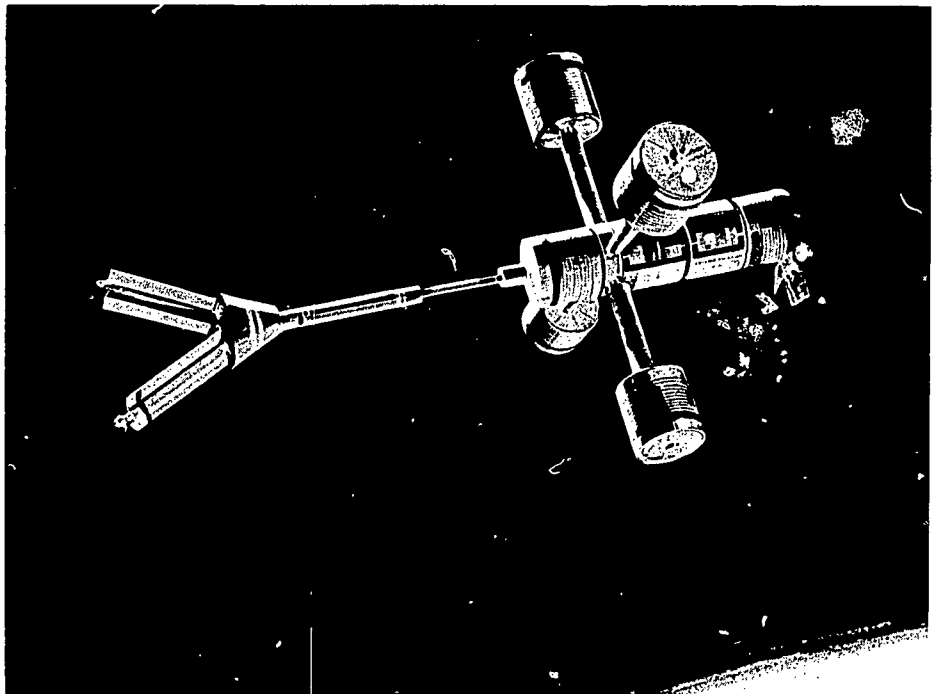

Concept of a Space Base cluster, by North American Rockwell, illustrates radial arrangement of Station modules to be rotated for simulating gravity. Y-shaped extension at left represents nuclear power supply and radiator panels.

and the second study undertaken by an industrial team headed by North American Rockwell has been monitored by the Manned Spacecraft Center. The purpose of these Phase B definition studies has been to generate basic information on the following aspects:

- (1) A preliminary systems design for the Space Station, along with appropriate development and operation plans.
- (2) A preferred Space Base concept, including a buildup plan covering details of how the Space Station or its derivative would be utilized in orbital assembly.
- (3) A concept for a planetary mission module, and the requirements

it could impose on the Space Station.

(4) Definition of the requirements and changes, if any, to the Space Station for performing geosynchronous and lunar-orbit missions.

(5) Evaluation of advanced logistics system concepts and requirements imposed by the Space Station and Space Base.

Additional supporting activity has included various small, competitive, primarily fixed-price contracts for studies and technological work related to Space Station Program definition. There are also numerous small cost-plus-fixed-fee contracts to principal investigator organizations, for the definition of experiments related to the Space Station.



OART WORK TOWARD SHUTTLE, AND RESEARCH HIGHLIGHTS

Oran W. Nicks*
Acting Associate Administrator for Advanced Research and Technology

Our Office of Advanced Research and Technology (OART) carries out a broad range of activities in aeronautics and space missions for NASA:

- We perform work oriented to the needs of the future, so as to provide technical bases for developments and missions that lie ahead, as well as to help solve problems that exist today.

- We try to carry new technology far enough to evaluate its practical potential, to demonstrate experimentally its advantages for adoption and use, and to help ensure the transition from research to application. This means many things — the incorporation of research results in new designs, the testing of new concepts by modifying existing equipment, the coalescing of numerous advancements over several years into new aircraft or space vehicle concepts and designs, and the experimental demonstration of improved aircraft or space vehicles.

- We provide supporting effort for the development and operation of specific new aircraft or space vehicles. This means we use our existing knowledge and facilities to help other NASA programs, government groups, and the private sector solve current development or operational problems, or prepare for new aeronautical and space developments in the immediate or near-term future.

Much of OART's work in advanced research and technology, during the Sixties, was generally oriented to applications on the Space Station and Shuttle projected for the latter part of this decade. We have held a number of special conferences on reusable vehicles, where new technical information was compiled and presented.



"The technology focused on the Shuttle and Space Station is contained in six programs: Space Vehicle Systems, Chemical Propulsion, Space Power and Electric Propulsion Systems, Electronics and Control Systems, Human Factor Systems and Basic Research. Although not directly involved, the Aeronautical Vehicles Program contributes to Shuttle Technology through work on hypersonic aircraft and air-breathing engines."

*Presently, Deputy Director of the NASA Langley Research Center.

The first of these meetings was a technical symposium held at the Ames Research Center in March 1958. Other conferences were held in 1960 at the Langley Research Center, one in 1964 at the Marshall Space Flight Center, and another in 1967 at the Flight Research Center. NASA and DOD, under the auspices of the Aeronautics and Astronautics Coordinating Board, conducted a joint study in 1965 and 1966 to assess the technology applicable to reusable boosters. Space Station technology also has received attention with a conference at Langley in 1962 and a joint Space Station and Shuttle Conference at Langley in 1969.

As agency planning last year began to focus on the concepts of a reusable Shuttle, those of us on the research side also began to focus our efforts on near-term applications. This process is, of course, in line with our mission to facilitate the introduction of technology into practical use. Our involvement ranges from analyzing the technology needed and concentrating current research and technology effort on critical problem areas, to direct support of the Office of Manned Space Flight (OMSF) and its contractors through the use of research personnel and facilities to test specific concepts and models. We have established teams within OART to work closely with OMSF, to identify and sort out our current and relevant tasks, to pinpoint problem areas, and to recommend additional work necessary to a concerted NASA effort on the Shuttle and Space Station. Efforts totaling 30 to 40 million dollars each have been identified in the OART program as relating to the Shuttle and Space Station. However, much of this technology is also applicable to other Earth-orbital applications and to other future missions.

The technology focused on the Shuttle and Space Station is contained



"The Office of Advanced Research and Technology performs work on the needs of the future, so as to provide technical bases for developments and missions that lie ahead, as well as to help solve problems that exist today."

in six programs, namely: Space Vehicle Systems, Chemical Propulsion, Space Power and Electrical Propulsion Systems, Electronics and Control Systems, Human Factor Systems, and Basic Research. Although not directly involved, the Aeronautical Vehicles Program contributes to Shuttle Technology through work on hypersonic aircraft and air-breathing engines.

Let's discuss some of the critical problem areas that cut across these programs as they relate to the Shuttle, and what OART is doing toward their solution.

OART Work Toward Shuttle

One concept of a two-stage Shuttle is outlined in Fig. 1, and compared in dimensions and weight to three other existing flight systems. The Shuttle is both a huge and complicated space vehicle and an airplane. And because it

combines the operational characteristics of both, its design represents a tremendous technical challenge. We are already at work on a formidable array of research problems that have been identified as of prime importance to the Shuttle; some examples follow.

Configuration Research: Major problems being studied in our Space Vehicle Program are: reentry heating; hypersonic, transonic and subsonic aerodynamics; stability, control and flying qualities at all speeds; and special operational problems such as hypersonic maneuverability, approach and landing, and ferry operations from factory or landing site to the launching area.

We have been undertaking an extensive research and advanced technology program in all of these areas, but much work remains to be done. Our studies have indicated that each design con-

THE SPACE SHUTTLE IS COMPARABLE IN SIZE TO EXISTING FLIGHT SYSTEMS

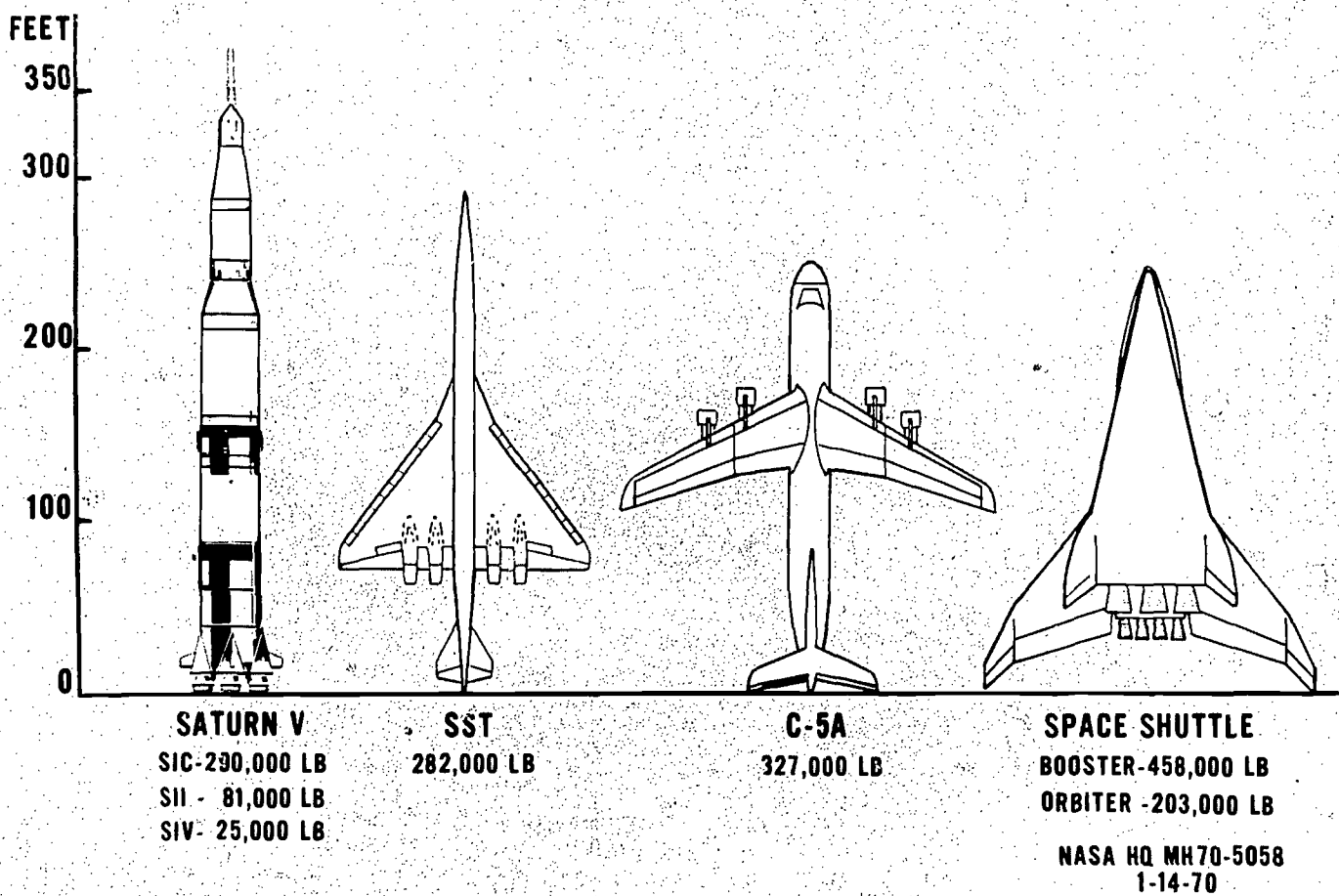

Fig. 1



"The Shuttle represents a tremendous technical challenge because it combines the operational characteristics of a huge and complicated space vehicle, and those of an airplane."

cept for the Shuttle has its own set of critical problems. In other words, all concepts are strongly configuration dependent.

For example, certain missions indicate a need for cross-range capability (flexibility to choose landing sites) from 1000 to 1500 miles. This capability has a significant impact on configuration, the thermal protection to be used, etc. And although we have made some cross-range feasibility studies, these have not been extensive enough to pin down cross-range implications in terms of additional weight, technological costs, operational expenses, delivery schedules, etc. We anticipate therefore, that continuing experimental research activity will be re-

quired in order to provide an effective technological basis for evaluation of the various candidate configurations, as well as to provide solutions to critical design problems.

Heat Transfer Research: Heat transfer is one of the major problems encountered during reentry by both the space orbiter and the booster stages of any Space Shuttle system. For example, wind-tunnel tests of an orbiter configuration under consideration indicated that temperatures along the nose and undersurface of the vehicle could be predicted, but a vortex type of flow formed on the side of the vehicle produced unpredictable regions of high temperatures. This unpredicted vortex impinged on the tail and caused a local regime of high temperature or a hot spot. This vortex heating was present on some configurations but not on all. But an important consideration here is that none of the methods in use today for estimating heat transfer would predict these unusual flow fields and high-temperature effects. Results such as these from the Space Vehicles Program provide convincing evidence of the need for extensive investigation.

Thermal Protection Research: The design and fabrication of the structure of both the orbiter and booster is one of the most critical areas in the development of a Space Shuttle. A truly practical and economical Space Shuttle must be of the lightest weight achievable and capable of multiple reuse, with minimum inspection and maintenance between flights. Fig. 2 indicates some of our structures and thermal protection research goals and problem areas indicative of the kinds of research and advanced technology activities which we plan to continue during FY 71.

The first of these is the development of design criteria. The objective of the design criteria effort is to insure

Fig. 2

STRUCTURES AND THERMAL PROTECTION RESEARCH

GOALS

- MULTIPLE REUSES
- MINIMUM WEIGHT
- HIGH RELIABILITY
- LOW-COST INSPECTION & MAINTENANCE
- SOUND TECHNOLOGY BASE (DESIGN CONFIDENCE)

PROBLEM AREAS

- DESIGN CRITERIA
- REUSABLE HEAT PROTECTIVE SYSTEMS
- HIGH TEMPERATURE INSULATION
- ADVANCED CRYOGENIC TANKAGE
- FABRICATION & TEST OF LARGE STRUCTURAL ELEMENTS
- STRUCTURAL DESIGN OPTIMIZATION
- NON-DESTRUCTIVE INSPECTION & TEST

BOOSTER

ORBITER

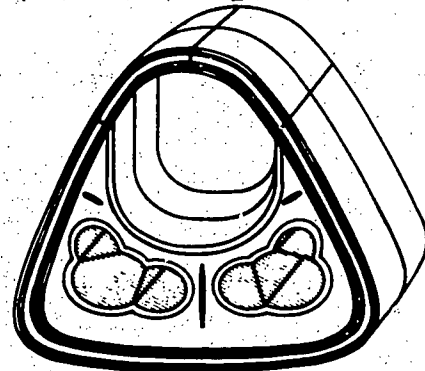
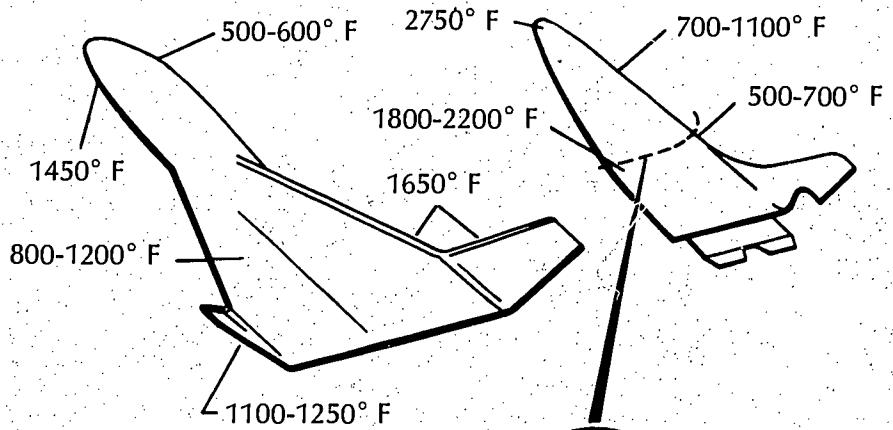

LARGE STRUCTURAL TEST ELEMENT

that the Space Shuttle is designed without unnecessary weight, excessive thermal protection, or other undue penalties for overdesign, so that it can not only perform its mission safely and reliably, but also economically.

Research and development to provide a reusable heat protection system is of major importance. Figure 2 reflects some of the operational temperatures predicted for typical booster and orbiter stages of the Shuttle. The best heat protection system would be one capable of a reasonable number of reuses without needing refurbishment. With careful attention to configuration design, it may be possible, for example, to protect a major portion of the orbiter surface and all of the booster's by currently available super-alloy materials. Only relatively small areas of the orbiter, that reach the highest temperatures will require the new high-temperature materials such as TDNickelChrome or coated columbium.

Another important research objective is to develop better high-temperature insulations. Areas of the Shuttle which experience extreme temperatures will require improved high-temperature insulations which are now in the early stages of development.

Since both stages of the Shuttle will contain large cryogenic tanks, extensive studies are required to determine whether or not these tanks should be integral with the primary vehicle structure. It is entirely possible that research results might indicate that it would be advantageous, from weight considerations, to use integral tanks in the booster stage, but that the high temperatures experienced by the orbiter might require internally-installed tanks insulated from the primary structure.

Another important question to be answered by research is whether to use internal or external cryogenic tank insulation. Many types of low-temper-

ature or cryogenic tank insulation materials, which will also endure high temperatures, will be required for use with various Shuttle components.

As indicated earlier, one of our goals is to develop optimized structural designs for minimum weight, high reliability, low-cost inspection and maintenance, and multiple reuse capability. To achieve these goals, it will be necessary to fabricate and test experimentally many unique and advanced structural specimens and some large structural elements. The lower righthand portion of Fig. 2 shows a sketch of how a large structural element might look. This particular element is a part of the orbiter vehicle which includes the cargo bay. Structural test elements such as this will include the heat-protection system, insulation, primary load-carrying structure, and cryogenic tankage. Advanced technology activities of this nature would include development of new fabrication techniques utilizing advanced materials, and various tests of full-scale structural components. In some tests, cryogenic fuels would be placed in the tanks and the test specimens subjected to intense heating.

Another area receiving attention in the structures research program is non-destructive inspection and tests for vehicle flight recertification. Because of the large size of the Shuttle stages, we are continuing to explore various ways and means by which the load-carrying structure and the heat-protection system can be thoroughly inspected — quickly and reliably.

Figure 3 shows two typical reradiative thermal protection systems for Space Shuttles. The principal differences are that the concept at the top has a metallic heat shield, while the one on the bottom uses a non-metallic or hardened compacted fiber heat shield. In the concept at the top, the area between the metal heat shield and the primary structure of the vehicle is

partially filled with a special low-density fibrous insulation to protect the primary load-carrying structure from the high temperatures experienced by the metallic heat shield. The metallic heat shield is attached to the structure of the vehicle by a unique arrangement of metallic clips.

In the non-metallic heat shield concept, the rigid fibrous insulation material which acts as the heat shield is bonded by an adhesive to the primary load-carrying structure of the vehicle. In this concept, the primary structure also serves as an integral tank, but, in addition, an integral cryogenic insulation is also shown.

These and other thermal protection concepts will be investigated in order to provide a basis for determining the most efficient, reliable and effective heat-protection system required to meet the stringent requirements of the Space Shuttle.

A typical distribution of orbiter dry weight is illustrated in Fig. 4. Here the importance of the structure and the heat shield, in determining weight, becomes obvious. Therefore, we are directing considerable effort in structural research and technology to ways of reducing weight. We think it might be possible to reduce both the structural weight and the total launch-weight of the Shuttle by about 25%, through the use of composite materials.

Lifting-Body Flight Research: Figure 5 shows a photograph of the three vehicles used in lifting-body flight research which is a part of the Space Vehicles Program. They are, from left to right, the U.S. Air Force X-24A, the NASA M2-F3, and the NASA HL-10. The Lifting-Body Flight Research Program has been underway since May 1964, and is being used to investigate some of the low-speed flight problems that will be encountered by both the Space Shuttle orbiter and the booster. The program is continuing to provide

Fig. 3 TYPICAL THERMAL PROTECTION SYSTEMS

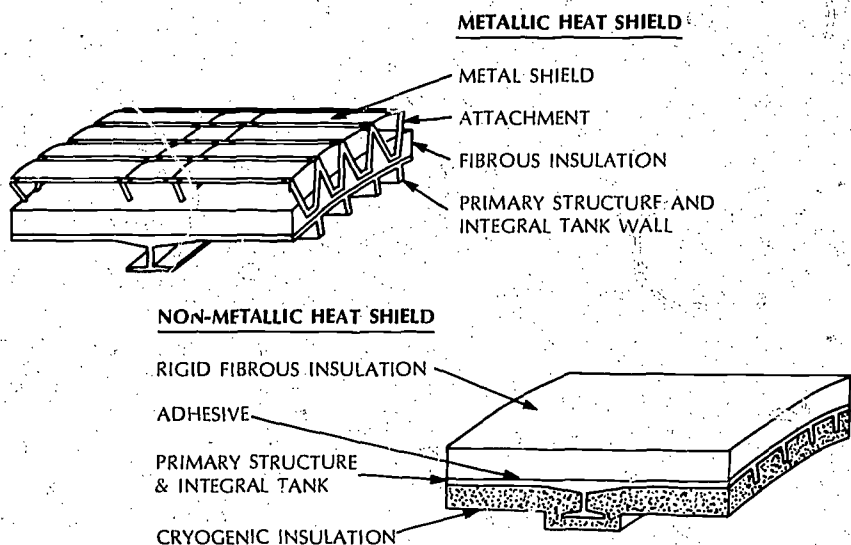
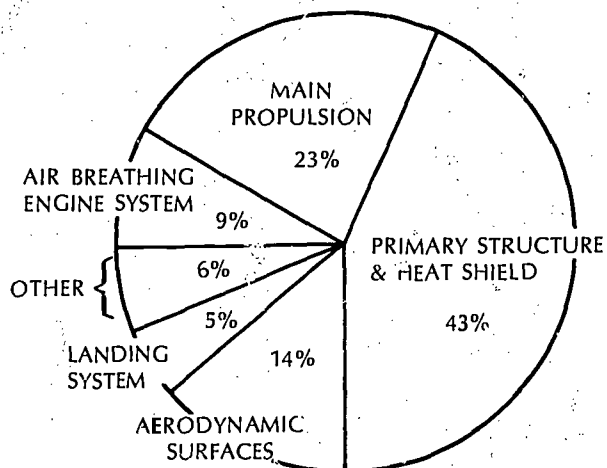
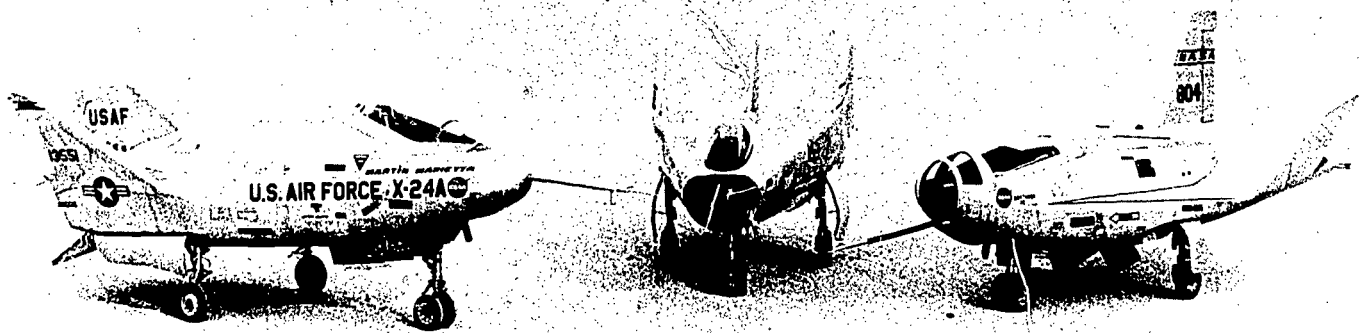

Fig. 4 TYPICAL DISTRIBUTION OF ORBITER DRY WEIGHT





Three "manned lifting bodies", the X-24A, M-2, and HL-10 are being flight-tested by NASA's Flight Research Center, in a joint NASA-USAF effort to provide data toward the design of the Space Shuttle.

information on subsonic and transonic flying qualities.

Integrated Electronics: Automated internal control, navigational and communications equipment — with self checkout capability — is needed if the Shuttle is to achieve cost-effective operation. The technology on which to base these developments is largely in hand insofar as components and subsystems are concerned. Prior to development there is, however, the problem of defining an optimum system to perform the required functions, identifying the desired characteristics of components and subsystems, and electronic system. Impressed on this effort are two imperative ground rules: The Shuttle must have autonomous operational capability, and it must be fully compatible with the Space Sta-

tion and the ground support installations. These requirements necessitate continuous and thorough coordination with similar efforts relative to the Space Station and ground installations, to assure compatibility among the various systems and commonality of subsystems and systems — where feasible and justified.

Principal efforts underway and planned in the electronics area, as part of the Electronics Systems Program, include research and technology in the areas of communications and tracking (antennas, sensors, transmitting and receiving devices); guidance, navigation and control (automatic and manual systems, terminal area guidance and control concepts, low visibility approach systems); and data systems (software technology, sensors and in-

strumentation, mass storage devices, data bussing techniques, component screening and reliability). Ames and Langley Research Centers and Marshall Space Flight Center are the major contributors to this effort.

Since the design of large-scale integrated systems is so complex, it is desirable that the entire process from design, through fabrication, to screening and testing be automated. We are putting major emphasis on automated testing because we think it offers an immediate payoff in improved reliability of large-scale integrated circuits and is necessary to meet the requirements of the Space Shuttle. Requirements for large-scale integrated circuit testing are: automated in-process testing, high speed, and versatility so that the test sequence can be easily modi-

fied to test different types of systems. Efforts are also needed to develop the necessary software to adequately test various types of large-scale integrated circuits. This work will continue in FY 71, with primary emphasis on development of the software or computer programming requirements.

Electric Power: Some major power processing technology challenges associated with the Shuttle are: weight reduction, on-board preflight power system checkout, automatic inflight failure detection and isolation, and commonality with the Space Station. Flight operations of the Shuttle may require very high peak powers for short durations for deployment of aerodynamic surfaces (e.g., wings), engine gimbaling and landing-gear actuation. Chemically-fueled turbines, commonly called Auxiliary Power Units (APU), which supplement the base load power system, may be required to meet these needs. One promising concept, related to our previous work on turbine systems, is a turbine-powered alternator and/or hydraulic pump power system which runs on steam generated by the combustion of hydrogen and oxygen. In FY 71, as part of the Space Power and Electric Propulsion Program, we plan to initiate a combined in-house and contractual effort to study specific APU configurations, develop preliminary design, identify technology problem areas, and initiate component procurement for development testing.

Other work is directed toward the power conditioning and distribution system to provide the requisite types and levels of power required by the numerous electronics and other subsystems. The Lewis Research Center is the lead Center in this work.

Biotechnology: The Shuttle will be a manned vehicle, accommodating both highly-trained and conditioned crew members, also non-conditioned passengers. Although the operating



"An important research objective for the Space Shuttle is to develop high-temperature insulations."

duration of the Shuttle is nominally in the same range that has been accomplished in manned space flights — indicating that major extensions of life-support technology probably will not be required — new effort will be needed to delineate optimum usage of safety for the human elements of the system.

The presence of relatively unconditioned passengers and Space Station personnel deconditioned from long durations in space in the Shuttle, will necessitate new investigations in the biomedical area to establish acceptable environmental bounds. We shall also need to develop special personnel restraint and support systems. In addition, some work on atmosphere sensing and control, environmental control, and water and waste management systems must be undertaken to meet particular environmental conditions peculiar to the Shuttle. Various aspects of the Shuttle biotechnology

program are under investigation at Ames, Flight, and Langley Research Centers, and at the Manned Spacecraft Center.

Operations, Maintenance and Safety: Only limited efforts have been undertaken in operations, maintenance and safety because the major influencing factors are heavily dependent on the particular Shuttle configuration and its associated operating mode. As other program elements lead to a better system definition, this activity will be amplified.

Underway and planned are the study and development of control and display simulation requirements, development of crew workload criteria for system monitoring, and development and simulation of techniques for personnel and cargo transfer and the associated extravehicular activity.

The Kennedy Space Center is the lead Center for operations, maintenance and safety work, and the Chairman of a Technology Working Group is located there. This Group is vitally interested in the integration of the elements of the Shuttle system. The Group maintains close liaison with the Working Groups on Integrated Electronics and Biotechnology; it also maintains liaison with: (a) the Flight Research Center, where much flight research pertinent to the orbiter part of the Shuttle is being conducted; (b) with the Manned Spacecraft Center, in relation to interfaces with the ground and flight operations systems; and (c) with the Space Station program.

When in the final analysis people ask "What is the value of these efforts and the role of the Shuttle in the future of man?" the answer may boil down to this: the real benefits to man will come from the applications payloads delivered by the Shuttle, to implement the operation of the orbiting Space Station; the Shuttle itself will serve to make these things possible at reasonable cost. **A**

OART WORK TOWARD STATION— TECHNOLOGICAL CHALLENGES

Oran W. Nicks*
Acting Associate Administrator for Advanced Research and Technology



"Through coordination with other government agencies and open channels of communications with industry and universities, an increasing number of non-space related applications are being found for the products of this NASA-generated technology."

*Presently, Deputy Director of the NASA Langley Research Center.

Major activity being directed by the NASA Office of Advanced Research and Technology to Space Station needs includes research effort related to the following aspects.

Artificial-Gravity Problems: To date, the question of whether artificial gravity must be provided for long duration space flights has not been answered. It may be required either for astronaut performance enhancement or for physiological reasons, or for both. One of the concepts being considered for the generation of intra-vehicular artificial gravity calls for rotation of portions of the space vehicle.

Because these systems involve large rotating modules connected with relatively long flexible members, dynamic response of the structure must be well defined so that stabilization and control systems can be properly designed. A problem here is to predict adequately the dynamic behavior during artificial-gravity evaluations. Accurate analysis of the structural dynamics requires experimental data which cannot be obtained with full-scale structures prior to flight. Consequently, simulation of the structural and operating characteristics in the laboratory will be necessary using advanced techniques for dynamic scale-model tests. Research will be directed to developing reliable techniques for such simulation tests, and to resolving dynamic problems unique to this mode of space station operation.

Environmental Protection: A vital design consideration for the Space Station is a ten-year orbital lifetime. As such, it will be logical to accept some possibility of repairable damage rather than overdesign against anticipated hazards. Since the loss of pressure and consequent loss of cabin atmosphere are of great concern, we need to develop sensitive leak-detectors and localizers to permit fast warning and identification of damage criti-

cality — particularly for inaccessible areas.

A major thermal problem of large, manned space vehicles is the design and development of efficient radiators for the rejection of heat from both internal and external sources. Radiators for large Space Stations require an extremely wide-ranging heat rejection capability, along with a rapid response to changing external temperatures.

We are developing techniques involving the use of heat pipes or fusible material heat sinks which will provide the faster thermal response required in radiators designed to use coolants such as freon, rather than water glycol solutions. We are also developing improved thermal control coatings which will maintain a low solar absorptance as well as high heat rejection capability over a long period of time.

Surface contamination has a major effect in degrading and thus increasing the solar absorptance of white spacecraft thermal control coatings. Not only is contamination by handling prior to launch a major problem, but the effect produced by the exhaust plumes of attitude control motors can be detrimental.

The possible effects of surface contamination on telescope and other optical surfaces utilized on a Space Station are obvious. Here the systems can be affected by minute amounts of contamination produced by reaction controls, by waste disposal, and by outgassing of spacecraft materials in vacuum. Therefore, an analysis of all potential contamination sources and hazards must be made to eliminate, or at least minimize such effects. We are pursuing a vigorous program to understand the problem, and then to determine what to do about it.

The dimensions of spacecraft now on the drawing board and in the planning stage far exceed those which were envisioned several years ago. Since the construction of consecu-

tively larger thermal/vacuum test facilities is not envisaged as spacecraft get larger, we must continue to improve techniques of thermal scale modeling, methods to verify new thermal design concepts, and tests of thermal performance of spacecraft.

Meteoroid Environment: We have plotted meteoroid frequency as a function of effective meteoroid mass using data obtained from Explorers XVI and XXIII, the three Pegasus spacecraft, and ground-based meteor observations. These data have been used to develop a generalized meteoroid environment model as part of NASA's Space Vehicle Design Criteria Program.

Some uncertainties still exist, however, in the region of interest for future manned missions. To meet immediate needs for Space Station design, we are investigating the feasibility of a low-cost thick-wall meteoroid penetration flight experiment, utilizing spent Saturn launch vehicle stages in orbit.

Electric Power: The electric power requirements of Earth-orbiting manned spacecraft to-date have not exceeded about one kilowatt of electric power. Further, these spacecraft have had to survive in space for a relatively short period of time. By contrast, the proposed Space Station and projected Space Base will require from 25 to 100 KW of power for periods of up to ten years. These requirements not only demand that higher power energy sources be developed, but also that new and more effective techniques for its distribution to the user in the Space Station be developed.

Thus, our Space Power and Electric Propulsion Program is concentrating on power technology developments for Space Stations in three areas: (1) high power-density, long-life energy sources, (2) high-efficiency power-conversion systems, and (3) multikilowatt,



"In conjunction with the Office of Saline Water, NASA has been searching for new and less-costly water-reclamation methods."

high-reliability power-distribution and processing techniques.

During FY 71, the Atomic Energy Commission (AEC) will continue its development of high power-density, long-life energy sources in support of manned space missions. Included in this activity are the SNAP-8 Uranium-Zirconium-Hydride thermal reactor and large Plutonium 238 heat capsules. We will also examine reactor designs of much higher efficiency that could eventually replace the Uranium-Zirconium-Hydride reactor. To a more limited extent, techniques for improving solar array system technology will also be pursued. In this latter area, emphasis will be directed to the structural dynamics of deployable solar panels having areas of up to 10,000 square feet, and to the evaluation of battery-cell technology aimed at a high power-storage capability and long-cycle life. Such data would be useful should we need to develop a large

solar/battery power system.

In FY 71 the high-efficiency thermal-electric power conversion effort will concentrate specifically on two systems: the Mercury-Rankine and Brayton engine. Although both concepts will be actively pursued, we expect the Mercury-Rankine engine to reach technology readiness first because all components have already been endurance-tested for more than 10,000 hours. On the other hand, the Brayton engine, because its potential operating efficiency is much higher than that of the Mercury-Rankine System, has good growth capabilities for even larger power requirements. In addition, the Brayton engine can also operate equally well with a radioisotope heat source, thus giving it a broader operational applicability. Both systems require extensive analytical and experimental efforts which involve a great deal of component, system, and life testing.

Multikilowatt, high-reliability power distribution and processing techniques are needed to efficiently handle up to 100 times more power than has been used in space. We know that current technology is inadequate to accomplish this task. We do not know what power distribution concept is best for our purposes. The form in which power is distributed (alternating current, direct current, voltage level, frequency, waveform) is of paramount importance in determining the type of electronic component technology which must be developed. These factors are of vital concern in focusing the technology program, which in itself will be a major task.

Information Systems: Studies have shown that checkout and fault isolation of the operational and support systems of a Space Station are of critical concern if we are to operate such systems for extended periods of time. The handling of the large masses of data associated with the operation

and utilization of manned Space Stations is another area of vital concern. Current estimates indicate that data loads will be several orders of magnitude greater than we have had to handle to date, approaching billions of bits of data per second. The program must also include related development of communications technology and, in addition, on-board position determination and guidance for support of experiments or resupply vehicles.

The FY 71 effort in the Electronics Systems Program will continue analysis of automated on-board checkout and fault-isolation systems that will assist in reducing the time and cost of launch operations. Work will continue on automated on-board methods for system-status monitoring for long orbital lifetimes independent of close ground-control. New effort will be directed toward the reduction of technology gaps in checkout software and error correction language, and the development of passive techniques for verifying the performance of radio communications systems.

Operation of the Space Station, its experiments and laboratories requires the development of new computer approaches that can handle high data-rates and, in addition, provide the flexibility to process many different kinds of data. A "multiprocessor" computer having modules of memory and processor capability, which can be automatically modified to overcome partial failures, will be studied. In addition, effort will be directed at the verification of multiprocessor techniques for Space Station applications. Work on a natural programming language compatible with a multiprocessor will be started so that special crew training in computer programming can be minimized.

It is anticipated that a tracking and data relay satellite will be utilized to transmit experimental inputs to the Station and results from the Station to

reduce the number of ground tracking sites. Thus, we plan to examine the design problems of new, lightweight Space Station antennas, high power C, S, or K band transmitters, and low-noise receivers that will be compatible with the relay satellite.

During FY 71 data coding technologies will be examined to determine what can be done to extend current techniques to the higher data-rates. Optical communication techniques, which look very promising will also be examined as a means for providing communications links between the Space Station and free-flying experiment modules.

With regard to position determination and pointing control, the program will contain work on advanced horizon sensors and "strapped-down" gyro/accelerometer systems. A laser radar will be redesigned and testing started to verify its capability to satisfy anticipated Space Station needs.

Control Research: In carrying out an extensive research program on control systems for large manned spacecraft, as part of the Electronics Systems Program, Langley Research Center has developed a simulation capability which can now be applied to mission research studies. The Langley simulation facilities provide for incorporating sensor and actuator hardware and the human operator in a simulated system, as well as simulation of all elements of the system.

Research efforts applicable to Space Station control system definition and development are under way. This effort is concerned with mission phases and is organized into the area of vehicle dynamics, stability, experimental control system functions, new operation efforts and control of subsystems. Efforts to date have: improved the steering and maneuver logic; identified a minimum-energy adaptive stabilization approach to reduce ground testing requirements for a

wide range of configurations anticipated for the Station; and developed and tested a monitor and diagnostic system for on-board failure detection and repair. These efforts will be continued.

In providing jet thrust for Space Station control, a major milestone was achieved in the development of resistojet technology applicable to manned Space Stations with the successful completion of endurance testing of ammonia and hydrogen resistojets.

During FY 70, initial tests were conducted on thrusters capable of operating on environmental control life support systems biowastes, such as carbon dioxide, methane, urine, and water. The operation of such propellant at high temperatures creates an environment which is hostile to most materials. Potential problems of oxidation, carburization or material deposition can exist. The crucial research problem therefore is in the selection of appropriate materials from which to construct the thrusters.

This work will continue in FY 71 along with research on necessary subsystem elements required to successfully integrate the biowaste system into the environmental control and life support system of a Space Station.

Life Support Systems: As the duration of man's stay in the space environment increases, it becomes tremendously important that life support and protective systems be highly reliable and maintainable. In addition, where weight constraints limit supply storage, or in the case of Earth orbit, where resupply can only be accomplished periodically, systems must be capable of regenerating vital supplies. Recycling of oxygen and water and management of human wastes will become essential. Consequently, oxygen and water recovery technology are receiving primary attention because the payoff in terms of weight-savings is greatest.

A 90-day test with a four-man simulator was conducted in summer this year for the Langley Research Center by the McDonnell Douglas Astronautics Company, Western Division. This NASA-sponsored run included an on-board oxygen recovery system with a water electrolysis unit. This water electrolysis device, a major component in the subsystem for oxygen recovery from carbon dioxide, was an advanced development completed by Langley Research Center on the basis of data obtained in their earlier 28-day manned test.

Other advanced subsystems were also tested during the 90-day run. Highly advanced subsystems for water recovery utilizing vacuum distillation and vapor pyrolysis with an isotope power source, as well as a water vapor electrolysis unit for humidity control were validated. A flight prototype atmosphere sensor and controller, and an advanced carbon dioxide removal unit were also tested for a comparison of their performance against previously tested equipment.

The odors and trace gases that can build up in sealed environments must also be removed or altered to less-toxic compounds. The functional unit that accomplishes this task consists of a large sorbent bed, a catalytic oxidizer and several small sorbent beds, a bacterial contaminant control unit (0.3-micron filters), and a particulate contaminant control unit composed of several debris traps and roughing filters. High temperature catalytic oxidation is the principal trace-gas contaminant-control device. It is a satisfactory process for the removal of methane, hydrogen, carbon monoxide, and many volatile organics present in the atmosphere. However, since some compounds (sulfur, for example) poison the catalytic oxidizer, pre- and post-treatment sorbent beds are required.

Activated charcoal also has applica-

tion for contaminant control, but the weight penalty involved constitutes a major drawback for very long-term missions. The results of studies aimed at charcoal regeneration by application of heat and a vacuum have been encouraging. Electrochemical regeneration methods are being developed in conjunction with the Federal Water Pollution Control Administration. Sorbent development programs also have application to air pollution control, and NASA is exchanging research data with the National Air Pollution Control Administration in this area.

As the projected duration of manned spacecraft missions is increased, the need to measure and control more accurately the partial pressure of major atmospheric constituents and trace contaminants also becomes increasingly important. Since the basic technology is for the most part already available, the developmental thrust has been primarily directed at miniaturization and packaging for minimum power and weight penalty and high reliability.

Processing of waste water and urine has long been recognized as a high priority item in regenerative life-support systems. The majority of the processes now under development for urine and condensate water recovery involve vaporization and subsequent condensation. Recovery in the 95 to 97 per cent efficiency range has been considered sufficient to effectively close the water loop. Catalytic oxidation of water, via vacuum distillation and vapor filtration, is one of the more competitive advanced subsystems available.

One significant penalty of distillation techniques is the cost in weight and power. NASA, in conjunction with the Office of Saline Water (OSW) has been searching for new and less-costly water reclamation methods. The result of this collaboration is the development of a highly promising wash-

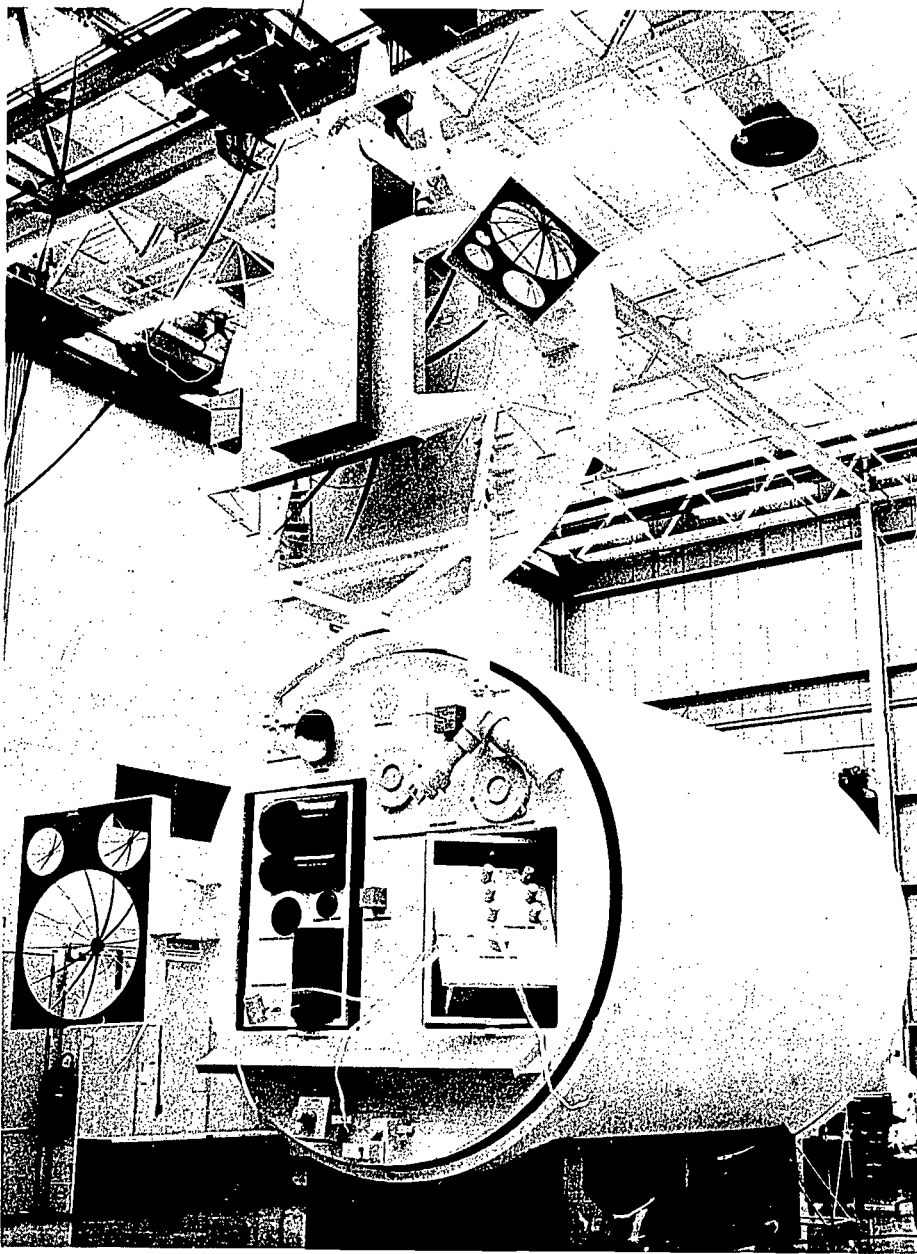

Full-scale mockup of General Electric Space Division's Earth Surveys Module displayed in semi-operational mode, with solar panel visible in retracted position in upper part of photo.

water reclamation technique based on the principle of reverse osmosis, that is, pressure filtration through a semi-permeable membrane, to remove solutes. Such a reverse osmosis unit has been developed by Philco-Ford Company for OSW and NASA.

As must be evident, psychological and physiological acceptance of current bag concepts for feces collection and urine dumping will decrease sharply for long-term space missions. Several advanced concepts are currently under development. The objectives of each of these are to: (1) collect, treat, and store all solid and liquid wastes; (2) eliminate odors, aerosols, and gases; (3) sterilize waste matter to inhibit or eliminate microorganism production, prevent production of gases, and prevent crew contamination; and (4) reduce storage mass and volume of waste materials.

Another advanced waste processing unit is being developed which is of interest to the Federal Water Pollution Control Administration in connection with sewage treatment techniques. It uses a technique known as high-pressure wet oxidation. Briefly, this system combines the wet residue from the water recovery subsystem with solid waste material and processes the mixture at about 550°F. Early laboratory tests showed that the gases and vapors evolved were principally non-toxic ones — water vapor and carbon dioxide.

A variety of government or industry-funded research programs are currently studying new foods for space flight, including frozen food packs, dried fruit packs, and canned foods. The most promising developments appear to be modifications of present freeze-dehydration methods to reduce volume and to enhance flavor along with such techniques as wet packaging. These approaches when tried so far have served to boost morale considerably.

For very long-term space missions logistical considerations indicate that, if at all possible, at least a portion of the food consumed by the crew should be regenerated. This would result in considerable weight and volume savings. At the present time, physiochemical regeneration of carbohydrates from expired carbon dioxide and water appears to offer the most promise. An estimated 50% of the diet could be provided in this manner. During the past year, there have been major advances in this approach as a result of efforts at the Ames Research Center.

Diets have been developed at Ames which contain only two or three chemically-synthesized pure nutrients. These diets fed to young animals did not impair normal growth, sexual maturation, or reproduction. Some groups of animals have been reared for three generations consuming only these diets.

Laboratory prototypes have been developed for synthesizing two pure nutrients, formose sugars and glycerol. They will be used to obtain data for the fabrication of automated miniaturized apparatus more suitable for aerospace evaluation.

Recently, several private organizations have expressed considerable interest in physiochemical nutrient synthesis. The commercial process would differ from the aerospace application process in that methane, rather than carbon dioxide and hydrogen, would be the raw material.

Astronaut Protective Systems: Although a shirtsleeve environment is planned for long-term missions, extravehicular activity still requires efficient spacesuits. Advanced spacesuits and reliable portable life support systems will be needed for the safe conduct of extravehicular tasks, such as repairs. Recent progress in these areas is described in what follows.

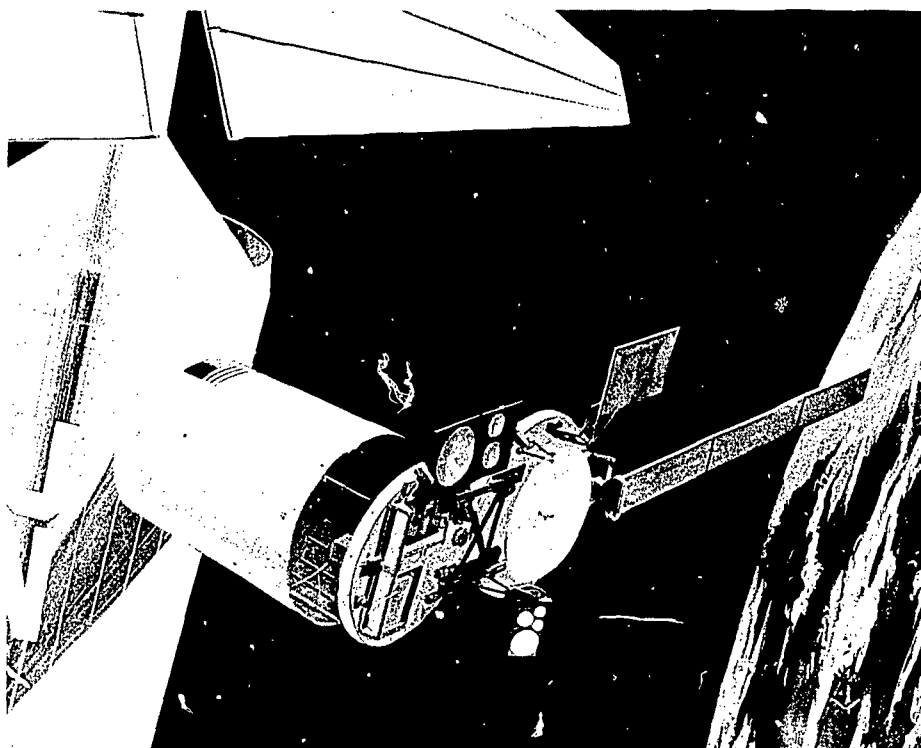

Conceptual rendition of General Electric Space Division's Earth Surveys Module depicted in operational mode, mounted on the Space Station in an Earth-scanning attitude.

The Manned Spacecraft Center contracted with the AiResearch Manufacturing Division of the Garrett Corporation to produce a spacesuit which featured the best capabilities of both the hard and soft spacesuit joints for extravehicular use. The AiResearch extravehicular suit utilizes the hard spacesuit derived "stovepipe" joint in the shoulder and hip areas, moulded "nesting bellows" convolutes in the elbow, waist, thigh, knee, and ankle sections, and a single-axis rigid-body closure with rotation capability.

The reduction in torque values achieved in all joint ranges represents a state-of-the-art breakthrough. Proof-of-concept has led to acquisition of this system under the Office of Manned Space Flight mission funding

for engineering design verification testing.

At the Ames Research Center, the development of the AX-2 hard spacesuit system has had for its technology goals the achievement of a totally hard structure system, proof of the stovepipe principle in complex joint systems, and a total operating pressure of 7 to 10 psia. The AX-2 hard suit program has successfully met its technology goals. Only the glove system still has soft components. Work has been initiated this year to study potential solutions to this problem.

The design goal of the metal fabric suit program is the establishment of a suit system which embodies in one fabric layer the capabilities for gas impermeability, abrasion resistance,

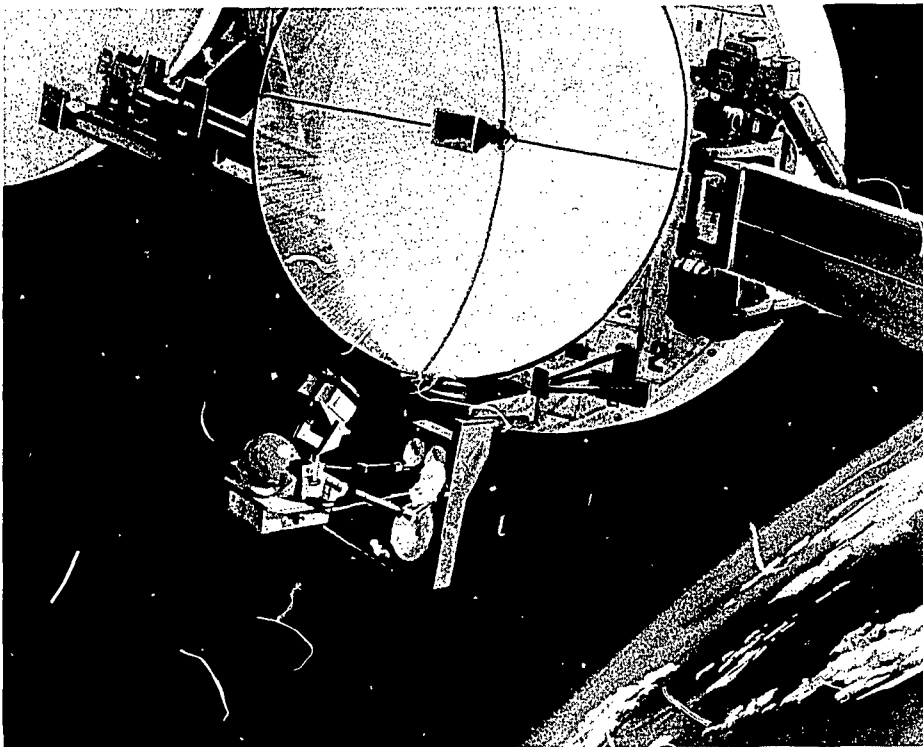

Artist's rendition of the General Electric Company Space Division's robot Teleoperator shown in process of replacing a sensor unit on the Earth Surveys Module.

and structural restraint—instead of three layers with one capability per layer. The Litton Systems, Inc., Applied Technology Division, is constructing such a suit system under contract to the Manned Spacecraft Center.

Human Research: Scientific data obtained during the more than 5,000 hours of manned space flight to date have done much to dispel speculation about man's ability to function for a short time in a weightless environment and to make the stressful transition to and from that environment. While results so far are encouraging, there is as yet no definitive answer to the question: "Are there subtle changes (in response to long-term weightless-

ness) which, as yet have been undetected? Are there changes which will appear only in prolonged flight?" This question was posed in 1967 by the President's Science Advisory Committee. Since that time a great deal of effort has been expended to provide the answers. Much has been learned, but much yet remains to be done if we are to "achieve a depth of understanding about man and his role in space that will permit his optimal integration into future space programs." This last requirement set forth by the President's Science Advisory Committee in November 1969 can be said to be the goal toward which the Human Factors Systems Program is working.

All the foregoing examples of re-

search effort represent only a portion of the work currently sponsored and directed by the NASA Office of Advanced Research and Technology, through the Space Vehicles Program, the Space Power and Electric Propulsion Program, the Electronics Systems Program, and the Human Factors Systems Program. The evolving technology has many applications, common to many needs both here on Earth, as well as in space. It is not surprising, then, that almost half of OART's space technology effort, is applicable to the Shuttle and the Space Station.

Through coordination with other government agencies and open channels of communication with industry and universities, an increasing number of non-space related applications are being found for the products of this NASA-generated technology. These applications can also contribute to increased safety in transportation systems, improved techniques in clinical medicine, new insights into human physiology, and techniques for environmental pollution control. **A**

DEVELOPING THE TECHNOLOGICAL BASE FOR THE SPACE SHUTTLE

Adelbert O. Tischler
Director, Chemical Propulsion Division
Office of Advanced Research and Technology

Molding the concept of a reusable Space Shuttle economical to develop, produce, and operate presents by far the most challenging technical task we have had in the space program. For we are dealing with a concept that will marry the most advanced states of aircraft and spacecraft technologies and then some more. And the foremost question we are now trying to answer is: how much more technology will we need, without risking escalating development costs? The answer will help us project the design of the Shuttle with some realistic cost estimates.

Technology Steering Group

To develop inputs toward these ends, the NASA Office of Manned Space Flight (OMSF) last year commissioned the Office of Advanced Research and Technology (OART) to develop a base of technological information and of experience—for judging the merits of various technical concepts on which to base a realistic design. Since the OART was functionally organized, it was in an advantageous position to structure a Shuttle Technology Steering Group to tap the specialized expertise residing at NASA's field Centers.

The Technology Steering Group is subdivided into seven Working Groups, each representing a technological specialty. Working groups are headed by senior technologists from the field Centers (see accompanying chart). The total advisory body represented by the Working Groups includes some 125 people, with about even representation from OMSF and OART. We also have ten representatives from DOD, distributed throughout the Steering Group.

What was done through the organization of this Technology Steering Group, in effect, was the superimposing of a project structure on top of an

existing disciplinary tree. The Steering Group and the Working Groups serve only in an advisory capacity; the actual management of funds and the boilerplating are accomplished through the OART and the OMSF.

All Centers Contributing

The development of the Apollo represented a massive challenge in communication and effort integration. Yet the development of the Space Shuttle and Space Station as a total system may pale the Apollo effort—one reason for this being that while Apollo involved the integration of effort mostly from the Marshall Space Flight Center and the Kennedy Space Center, the Shuttle and Station will draw from the technological resources of all the Centers.

We have a wealth of technology developed during the Sixties, but we also have sizeable gaps in the total spectrum of know-how needed for predicting costs realistically. It would be foolhardy to make technological or cost projections without a firm footing in all the major areas of expertise because of the extent of interdependence of these areas in shaping the success of the Shuttle.

For example, our studies indicate that there is a critical relationship between the performance of a two-stage Shuttle and its mass—to the extent that a one percent change in main propulsion performance is equivalent to almost one quarter of the payload to be put in orbit (in-orbit payload represents 1.0 to 1.5% of the Shuttle's take-off mass). Considering that the Shuttle's propulsion systems and structural as well as thermal protection materials would be extensions of current technology, it would be difficult to overstate the importance of having some real livable numbers based on experience in these areas.



"What is a functional interface? It is a hypothetical boundary which is opaque from both sides... Human nature being what it is, interfaces can never be eliminated completely. But when common goals can be agreed upon the interfaces lose some of their opacity."

Unprecedented Integration

Another unique aspect of the Shuttle's design will be an unprecedented extent of systems integration, and autonomous on-board checkout. Systems integration should, for example, be to the extent that the Shuttle's guidance, navigation, control and communication systems should be able to interplay with each other and present the pilot with only what he needs to know for his decision-making. Man is superior to machine in absorbing and judging new information, but inferior to computers and machinery in performing routine and repetitive tasks.

Invisible Boundary

As I said earlier, our basic challenge in pulling together the resources and technological information needed for the Shuttle, is communication — communication across countless interfaces: inter-organizational, inter-personal and functional. And what is a functional interface? It is a hypothetical boundary which is opaque from both sides . . . In this respect, I feel my function is essentially to increase the translucency of interfaces in this effort. Human nature being what it is, interfaces can never be eliminated completely. But when common goals can be agreed upon interfaces lose some of their opacity.

"We need total visibility of all the things being done in the name of the Shuttle, to make the needed decisions based on scientific and engineering judgement, independent of political judgement."



"While the Apollo program involved the integration of effort mostly from the Marshall Space Flight Center and the Kennedy Space Center, the Shuttle and Station programs are drawing from the technological resources of all the NASA Centers."

Formal Reporting Procedures

We have a fairly formal reporting procedure to promote the flow of information from over 100 individual on-going efforts in the Shuttle technology program which spans seven NASA Centers. Each effort reports monthly both to managing NASA Headquarters Divisions, and to cognizant Technology Working Groups. These Groups then summarize the inputs from all the tasks being performed, and they evaluate and report results to the Technology Steering Group. The Steering Group — composed of chairmen of Working Groups plus senior personnel from the Centers

and Headquarters — then feedback down to specific efforts to shift emphasis or initiate new studies as needed. It is the responsibility of the Technology Steering Group to survey the total effort for deficiencies, and to integrate the results of studies from the various disciplines into answers to our technological questions.

Our reporting procedure is on a fairly detailed format. We need total visibility of all the things being done in the name of the Shuttle, so we can scan the total effort for trouble spots. We need this kind of visibility to make the needed decisions based on scientific and engineering judgment, independent of political judgment. **A**

SPACE SHUTTLE TECHNOLOGY EFFORT

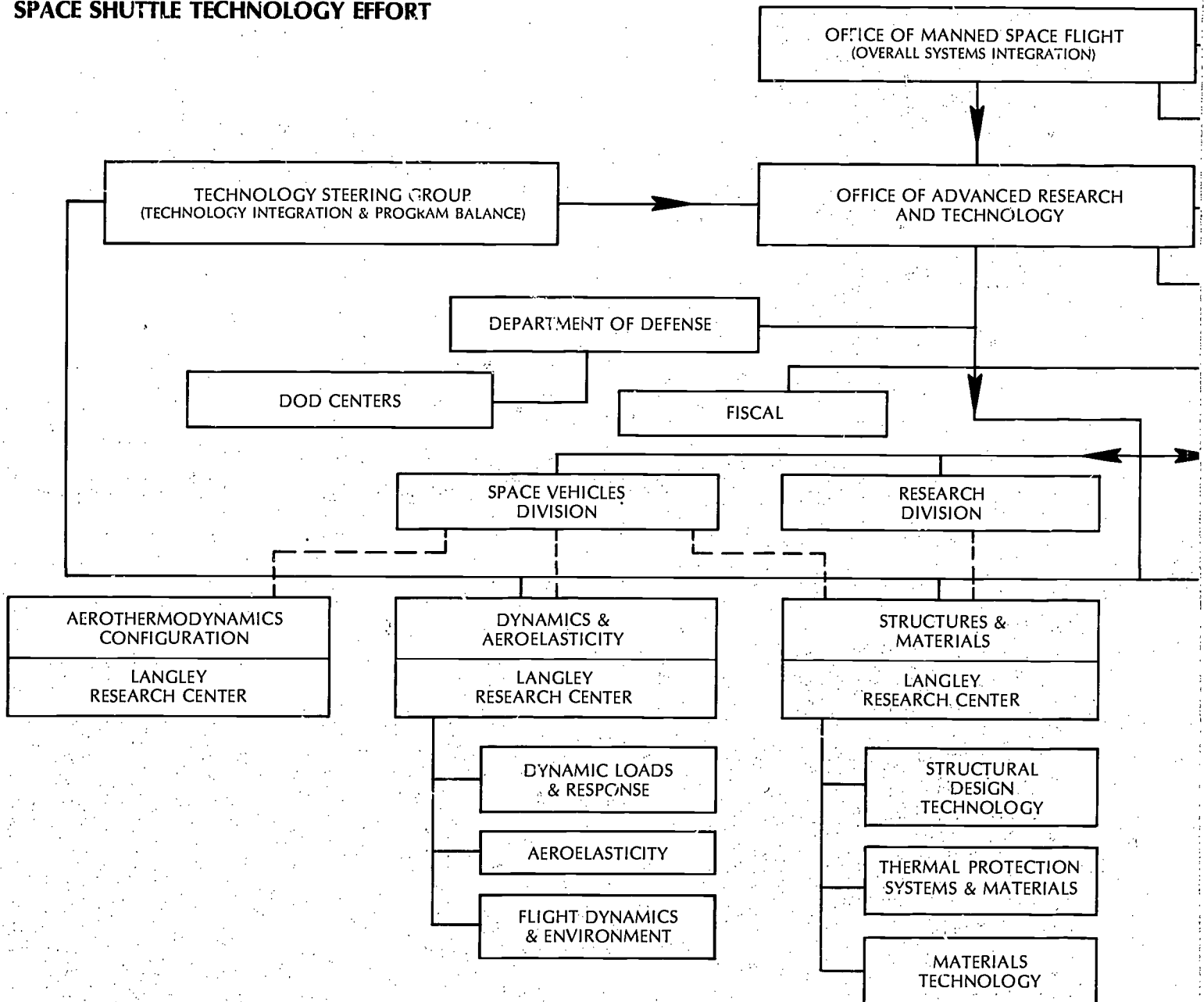

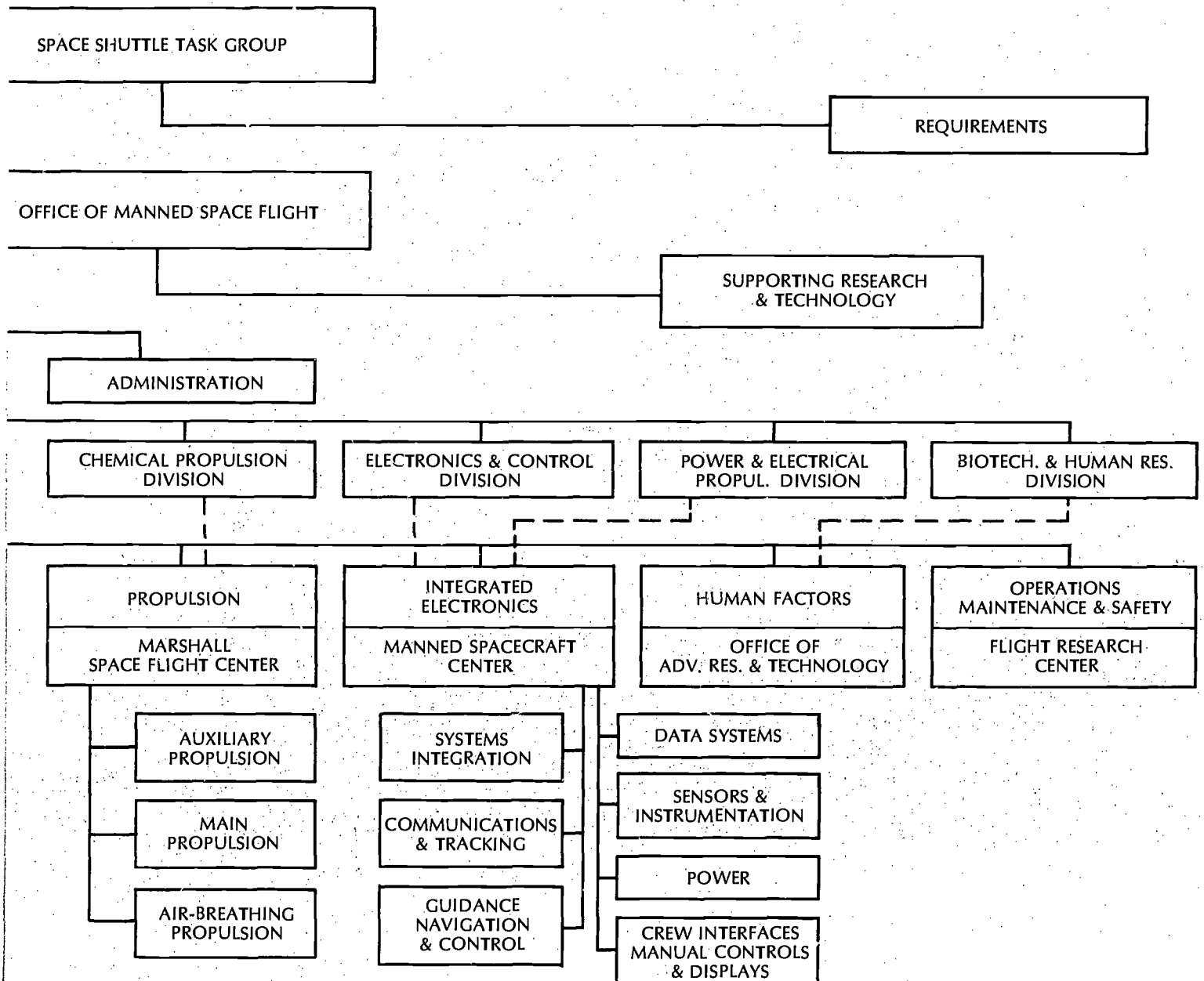

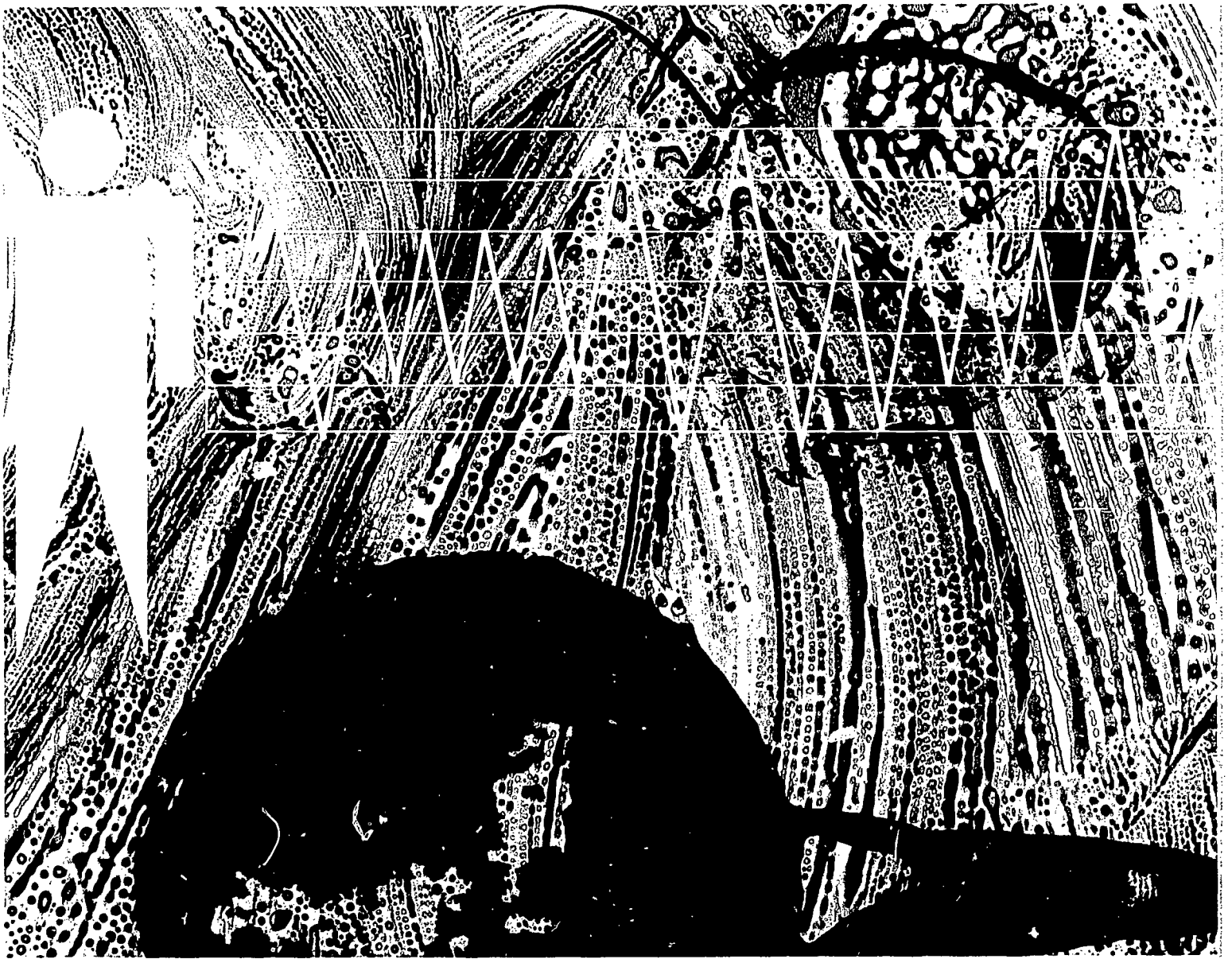

AIM OF MEDICAL EXPERIMENTS PROGRAM: TO BETTER KNOW EARTH-MAN IN SPACE



Interview with Dr. Sherman P. Vinograd
Director, IMBLMS Program and Research and Technology

Broad Medical/Behavioral Experiments Program for evaluating human system changes induced by space flight may advance diagnosis and therapy in Earth's environment

*"Know then thyself, presume not
God to scan;*

*The proper study of mankind is
man."*

Alexander Pope (1822-1892)

"Know thyself!" – the precept said to be coined by Socrates and a few of his lesser-known colleagues, some 2400 years ago – spells the basic purpose and motivation for any of our efforts related to NASA's Life Sciences Program.

Meaningful discussion of projects and concepts in this field of activity requires the highlighting of program contexts and kinships. For example, NASA's overall Life Sciences Program includes two major and related fields, Space Medicine and Space Biology. Space Medicine is concerned with the task of understanding man as a functioning whole, and with safeguarding his well-being while he is engaged in space operations and exploration; Space Biology is aimed at utilizing the unique environment of space – unhampered by the regulating influences of Earth – to increase our understanding of the detail processes of human life and those of other living organisms. The ultimate objective of both fields of study is to know more about man – the prodigious product of this uncommon planet.

As man's successful but short space visits, in the early Sixties, began firming the foundations for the longer ones to come, information on the effects of the new environment became of vital importance. We realized, as far as aerospace medicine and its technology were concerned, that we needed to extend: (1) our knowledge about the long-term biomedical and behavioral characteristics of man in space, and (2) to provide means whereby his physiological capabilities in the space environment might be enhanced for long-duration missions.



"A general philosophy of the Medical/Behavioral Experiments Program has been to plan experiment flight-schedules to explore known or expected problems, as well as to conduct human systems monitoring across-the-board, as much as practicable."

Early Flights for Engineering

The primary orientation of our first manned space flight program – Project Mercury – was toward demonstrating that the overwhelming engineering problems of space flight could be overcome. Accordingly, during the Mercury missions, and the follow-on Gemini, the concern of the medical scientists centered mostly on assuring man's support in space and his safe return to Earth – while predetermined engineering goals were being achieved. The Gemini Program did carry some medical experiments, but again these were secondary to the engineering objectives of the missions.

Unlike the Gemini Program, the current Apollo Program does not

undertake formal medical experiments for learning more about the biomedical changes of man in space. The medical experience from Gemini indicated what could be expected of man's physiological capabilities on a two-week mission. Therefore, the shorter-duration Apollo missions, from a biomedical sense are merely adding breadth to the manned space flight experience; the Apollo Program now in progress represents an extension of the application of the traditional principles and practice of aerospace medicine to include the lunar environment.

Apollo's Medical Requirements

Medical requirements for Apollo are dictated by three objectives which

have been constant throughout the entire manned space program: (1) crew safety; (2) medical information required for mission management; (3) continued study of biomedical changes in man as a prelude to longer-duration missions. These objectives are being met by gathering medical information through three methods:

- Ground-based measurement, or previous flight data gathered as baseline information for operational profiles.

- Monitoring of heart rate, respiratory rate, and body temperature during missions, by physicians on the ground, as well as verbal reporting of flight crews.

- Extensive pre- and post-flight medical examinations.

Even as early as in 1963, we could see that truly intensive biomedical studies have to be projected for the longer-duration capabilities of post-Apollo programs. But the Apollo Applications Program (now called Skylab), which was to become the first orbiting research laboratory for such purposes, was far in the future. So we had to keep our interim biomedical objectives on the limited capabilities of the Gemini Program. Thus, a Medical/Behavioral Experiments Program began in 1963, with a study of the Biomedical Experiments Working Group — an ad hoc group of NASA life scientists who devoted a series of meetings to an evaluation of the medical and behavioral aspects and requirements of an orbiting research lab. This was followed by two study contracts, to explore these questions in greater depth. One contract was with Republic Aviation, the other with North American Aviation.

Start of Intensive Studies

In January 1964, the Space Medicine Advisory Group (SPAMAG) of 20 prominent consultants of the medical

community began its in-depth study of this problem. The report of this group was followed by a series of eight two-day meetings chaired jointly by the NASA and the DOD.

A Technical Advisory Committee of ten NASA Centers and Headquarters Life Sciences specialists was called together in February 1965; their mission was to assemble, from the four reports resulting from the work thus far, a group of potential medical and behavioral experiments for an orbiting laboratory program. This was part of an investigation directed by Dr. Robert Seamans (then NASA's Deputy Administrator) resulting in the formulation of 23 medical/behavioral experiment concepts, as a representative package of medical experiments for the orbiting lab. Shortly thereafter, this group of pseudo-experiments was reassembled into eight component areas of body function: neurological, cardiovascular, respiratory, metabolic and nutritional, endocrine, hematological, microbiological and immunological, and behavioral. Each of these areas has its own list of required measurements and procedures. This list has been reviewed and updated repeatedly with the aid of our consultant advisors, the Biomedical Subcommittee of the Science and Technology Advisory Committee (formerly the Medical Advisory Council). The total measurement requirements for the evaluation of the above eight component areas of body function were eventually incorporated into the capabilities of a system which came to be identified by the acronym IMBLMS — Integrated Medical Behavioral Laboratory Measurement System — which I shall discuss in some detail later.

First tests of the medical/behavioral experiments of the program were conducted aboard Gemini spacecraft, in 1965. The Gemini package consisted of eight experiments, several of which

were flown on more than one mission. As originally conceived, the medical/behavioral experiments plan for the Apollo Program was an expansion of the Gemini package. But changes in the Apollo flight program ultimately restricted these plans to the extent that only three pre- and post-flight experiments were implemented. The remainder have been projected for use later in this decade, when the orbiting Skylab becomes a reality. Thorough medical operational evaluation, however, continues to be carried out in Apollo.

Technology and Methods

The initiation of the medical/behavioral experiments program in 1963 signalled the establishment of a new goal beyond the development of life-support technology – the development of technology and methods, also for evaluating the changes in human functions and capabilities that might be induced by space flight. Such an evaluation was addressed to answering a number of top-priority questions, the answers to which would provide a clearer delineation of man's capabilities and role in the man-machine systems of spacecraft. These questions are grouped as applicable to the eight component areas of body function we discussed earlier. A few typical questions in the cardiovascular area, for example, are:

- How are venous compliance and central venous pressure and their adjusting mechanisms influenced by prolonged space flight?
- How is cardiac function affected by long-duration space flight?
- What are the factors of space flight which cause changes in circulating blood volume and its distribution? At what point and under what conditions is a new equilibrium established? Etc.



"Space medicine has already had very significant, although largely indirect, influence on health care as evidenced in a number of ways: in the use of bioinstrumentation in intensive care units, in computer technology for more accessible and quickly available medical data, and in dynamic (as opposed to static) electrocardiographic and other evaluations for the earlier identification of potential medical problems."

Two Major Objectives

It should be stated for the purpose of gross orientation, that the total list of top-priority questions referred to earlier constitutes our detailed approach to the two major categories of our program's objectives. In the first category, which is oriented to manned space flight, we need to determine as precisely as possible man's medical and behavioral responses, functional limitations, the time course of the effects of space flight, means of prevention or correction of undesirable effects, supportive requirements in space flight, etc. This information will be applied to the substantiation of man's role in man-machine systems, and to the planning of future missions.

Our second major category of objectives is oriented toward Earth-based medical science. Our purpose in this respect is to advance medical science through experiments designed to utilize the unique environmental characteristics of space, without a primary interest in applying any resulting findings to space flight. For example, any physiological function which might be considered to be gravity-dependent in some respect is potential subject matter for investigation in the space environment.

Major Conceptual Approaches

Efforts directed toward these objectives are guided by several conceptual approaches that should be explained briefly to clarify the scope of the Medical/Behavioral Experiments Program. The following are some of the major approaches used:

(1) Principal investigators in this Program are not necessarily NASA personnel. It must be recognized that the Space Program is national in scope and broadly scientific in nature; the installation of experiments aboard spacecraft is expensive; and flight op-

portunities are sparse. For these reasons, NASA places strong emphasis on the participation of highly competent individuals of the national scientific community as principal investigators — regardless of their affiliations.

(2) A general philosophy of the Program has been to plan experiment flight schedules to explore known or expected problems, as well as to conduct human systems monitoring across-the-board, as much as practicable. Had this not been done in the Gemini Program, we would still be unaware of the red blood cell and fluid compartment changes which were discovered.

(3) Regarding the technical content of the Program, the major variable is the duration of flight. The most intriguing unknown factor is prolonged weightlessness. This does not, by any means, imply that weightlessness is the only factor of interest, nor does it imply that it will necessarily turn out to be the most important. However, it is an important factor and it remains unknown because of our inability to reproduce it on Earth.

(4) With respect to the question of artificial gravity, the Medical/Behavioral Experiments Program seeks to establish the need for it by evaluating flight crews who operate for increasing periods without gravity. Shorter missions can provide the opportunity to investigate artificial "g" techniques consistent with optimal crew, spacecraft and mission function, and performance. However, until the role of gravity can be determined, we feel that artificial "g" should be considered — at least initially — as a design feature of future spacecraft.

(5) As humans we are characterized by a broad range of individual responsiveness to any given set of conditions. This fact, and the relatively small number of flight crew members participating in space missions, necessitate the repetition of most ex-

periments to establish statistical validity of the findings.

(6) Lastly, the Medical/Behavioral Experiments effort must be viewed as a continuing one, serving and being served by a succession of flight programs of different durations. As these experiments fulfill various investigations related to space flight and to Earth-based medicine, the Program will be continually revised to accommodate refinements and new studies, and to discontinue those which can be considered completed.

Functional Organization of Program

For program management purposes the Medical/Behavioral Experiments efforts have been structured functionally into two mutually-dependent groups of activity as shown in Table 1. The first group (I) includes the experiments themselves — their planning, solicitation and management during both the definition and development phases. One aspect here, item 1B in Table 1, deserves additional explanation. The process of reviewing experiment proposals for scientific merit, used since 1966, involved two steps: a review by the NIH Study Section System, and a succeeding evaluation oriented primarily toward manned space-flight capabilities and requirements. The second evaluation was made by a highly qualified team of medical consultants to NASA (established in May 1965 as the Medical Advisory Council) now known as the Biomedical Subcommittee of NASA's Science and Technology Advisory Committee.

As mentioned earlier, the Medical/Behavioral Experiments Program is presently organized into the exploration and evaluation of eight areas of human function. Components of these eight areas make up the individual experiments in development for the Skylab, and four experiments in process of definition.

Table 1

**FUNCTIONAL ORGANIZATION
OF MEDICAL/BEHAVIORAL EXPERIMENTS PROGRAM**

I. MANAGEMENT OF MEDICAL/BEHAVIORAL EXPERIMENTS

- A. Determination of requirements and maintaining relationships, support, and participation of the scientific community.
- B. Review of experiment proposals for scientific merit.
- C. Support of experiments in definition.
- D. Selection, conversion, and support of experiments for development phase.
- E. Support and guidance during operational data gathering, and post mission data reduction and reporting phases.
- F. Application of data to the Medical/Behavioral Experiments Program, manned space flight, and the civilian community as indicated.

II. R&D SUPPORT OF MEDICAL/BEHAVIORAL EXPERIMENTS PROGRAM

- A. IMBLMS (Integrated Medical and Behavioral Laboratory System).
- B. Parallel development efforts to advance status of the art in measurement techniques and equipment to enhance the capabilities of IMBLMS and proposed experiments.
- C. Simulations and ground-based data, i.e., the support of ground-based simulation and other studies in order to obtain a body of pertinent data as a normative or control base, to permit the extraction of valid conclusions from flight data.

R&D Support

Turning again to the functional organization of the Medical/Behavioral Experiments Program (Table 1) let's consider the activities grouped under item II, the R&D Support of the Program. Task IIA consists of the Integrated Medical and Behavioral Laboratory Measurement Systems

(IMBLMS), introduced earlier. IMBLMS identifies the development of a highly flexible and sophisticated laboratory system for accommodating the medical and behavioral measurements required for existing and anticipated experiments.

The Medical/Behavioral Experiments Program presents some unusual-

ly challenging aspects; it is an effort to gain sound scientific knowledge of human responses to an unknown environment through research in a medium which requires hard, complex and predetermined engineering and operational interfaces. The IMBLMS concept was devised to meet such requirements by featuring maximum internal flexibility (through modularity) with minimal impact on its basic envelope of external needs.

Basically, IMBLMS consists of a rack-and-module system which can be assembled into working consoles to suit the requirements of the spacecraft and the experiments program of the particular mission. Hardware modules or submodules for any projected specific experiment can be developed for accommodation in the IMBLMS and used as needed.

Five Functional Elements

Flexibility of the modular approach is aimed at significantly reducing lead times, simplifying in-flight maintenance, and providing for the economical updating of equipment. The current concept of IMBLMS incorporates five functional elements: physiological, behavioral, biochemical, microbiological, and data management. These five elements together will accommodate the required measurements in all eight human measurement areas of the medical/behavioral investigation. The IMBLMS will be composed of two or three consoles, plus five or six pieces of peripheral equipment. Presently identified peripheral equipment includes: a bicycle ergometer, a rotating litter chair, a body-mass measurement system, a lower-body negative-pressure device, and a specimen-mass measurement system.

The IMBLMS measurement capability was derived from the previously mentioned 23 Medical/Behavioral Experiments formulated in 1965. At that

time we needed to time-line these 23 pseudo-experiments. We decided to do that by extending an existing study contract with Lockheed. They were to build a mock-up of a Medical/Behavioral Laboratory in a mock-up of a Lunar Excursion Module, and time-line these measurements with crew suited and unsuited. This was accomplished as a four-month effort which ended in February 1966.

Chronology of IMBLMS

In our first draft work-statement, in March 1966, we defined the modular and highly flexible IMBLMS concept, including prefabricated rack mountings, interfaces, etc., and began preparations for Phase B final definition of this Phased Project Procurement. A Request for Proposal was distributed and responses received. In April 1967 General Electric's Space Division and Lockheed Missile and Space Company's R&D Division were selected, and Phase B work started in June 1967. This phase has actually consisted of four steps or subphases extending from concepts through bread-board development, and on to preliminary flight design. Phase B4 will end later this year; it will be followed by the selection of a single contractor, and the initiation of Phase C, detail design, in early 1971. According to present plans, IMBLMS hardware will be available for flights of this decade.

Let's refer once more to the functional organization chart of the Medical/Behavioral Experiments Program (Table 1) and discuss briefly items IIB and IIC, to complete the picture.

Task area IIB consists of a series of independent grants and contracts aimed at further refining measurements techniques and equipment to augment the capabilities and accuracies of the IMBLMS. This is an important task area for many reasons, a major one being that many standard



"By pointing to its own unique needs for bioinstrumentation and telemetry, NASA played a catalytic role in the rapid growth of this field."

techniques are not adaptable to the environment and other circumstances of manned space flight. Also, most of these requirements were identified several years ago and can benefit by new viewpoints. There is still work needed especially in such areas as behavior, biochemistry, microbiology, energy metabolism during suited activity, accurate determination of fluid intake and output measurement, venous pressure and cardiac output techniques, etc.

The last R&D task area, IIC, consists of chamber studies, bed-rest studies, and similar types of simulations as sources of essential ground-based data. Individual principal investigators do obtain ground-based or control data as part of their experiments. Nevertheless, economic considerations dictate that evaluations of certain environmental factors — such as spacecraft atmosphere by long-term chamber studies, weightlessness effects simulated by bed rest, etc. — are best made by

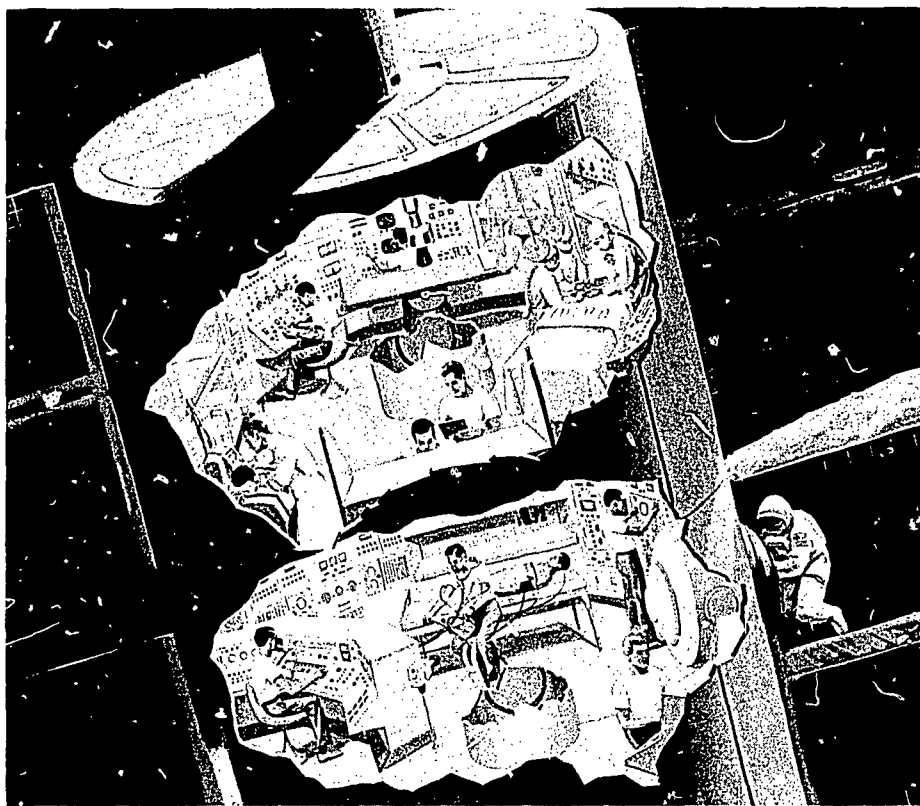

Artist's rendition of IMBLMS concept, which would include two or three consoles, plus five or six pieces of peripheral equipment. Presently identified peripheral equipment includes: a bicycle ergometer, a rotating litter chair, a body-mass measurement system, a lower-body negative-pressure device, and a specimen-mass measurement system.

NASA, with the participation of all principal investigators whose flight findings would be influenced by these aspects of the environment.

Impetus to Bioinstrumentation

I believe that NASA has succeeded in providing impetus to the whole field of bioinstrumentation. This is not meant to imply that NASA created this field, but that by pointing to its own unique needs for bioinstrumentation and telemetry, NASA played a highly important and effective catalyst role in the rapid growth of the field. Other new needs, and the needs for refining existing medical techniques are continually being identified; the results of the studies and developments generated by these needs are likely to be useful in a broader sense than aerospace applications. We need, for example, to devise non-invasive methods of determining cardiac output, central and peripheral venous pressure, deep regional blood flow, etc. For purposes of convenient biochemical analysis in the space milieu, we need reagents that are non-toxic and non-liquid, or techniques which avoid the use of chemical reagents altogether. And in general, we need to improve the accuracy and practicality of our measurement techniques. Lastly, there is also a unique requirement in this type of directed research, which is rarely if ever mentioned. This is the need to compress new technique evaluation and verification time-spans, in order to establish accuracy, reliability, repeatability, and in some instances interpretability.

Testing Man in Motion

An interesting paradox exists between the practice of medicine in the environment of the Earth and that in space: in Earth's normal environment medical science is oriented to the



"For purposes of convenient biochemical analysis in the space milieu, we need reagents that are non-toxic and non-liquid, or techniques which avoid the use of chemical reagents altogether."

study and treatment of man's abnormal conditions, and measurements are made mostly in his static state; whereas aerospace medicine is oriented to the study of essentially normal man in his active working state — within an abnormal environment. One result of the association of these different viewpoints has been the new trend of monitoring and recording human biomedical data, on Earth, during man's normally active state. NASA Headquarters, and now many other organizations, have been using portable, Walkie-Talkie size devices for recording biomedical data as part of annual checkups — while the subjects are in process of their normal daily activities.

Influence of Space Medicine

NASA's program of medical experiments can perhaps be considered unique in that it is a program of directed or goal-oriented research, centered on a set of rather unusual requirements. Yet, this work is an integral part of medicine and medical

research in general. As we progress in our efforts this fact will become more apparent.

Space medicine has already had very significant, although largely indirect, influence on health care as evidenced in a number of ways: in the use of bioinstrumentation in intensive care units, in computer technology for more accessible and quickly available medical data, and in dynamic (as opposed to static) electrocardiographic and other evaluations for earlier identification of potential medical problems.

I believe that as we continue these endeavors, applications to clinical medicine in the form of specific technologies, information and approaches — as well as those due to stimulation of certain areas of research — will increase exponentially. With the growing interest of clinical medicine in the relationships of the environment with health, the contributing influence of space medicine, which is a form of environmental medicine, is destined to be even further enhanced. **A**

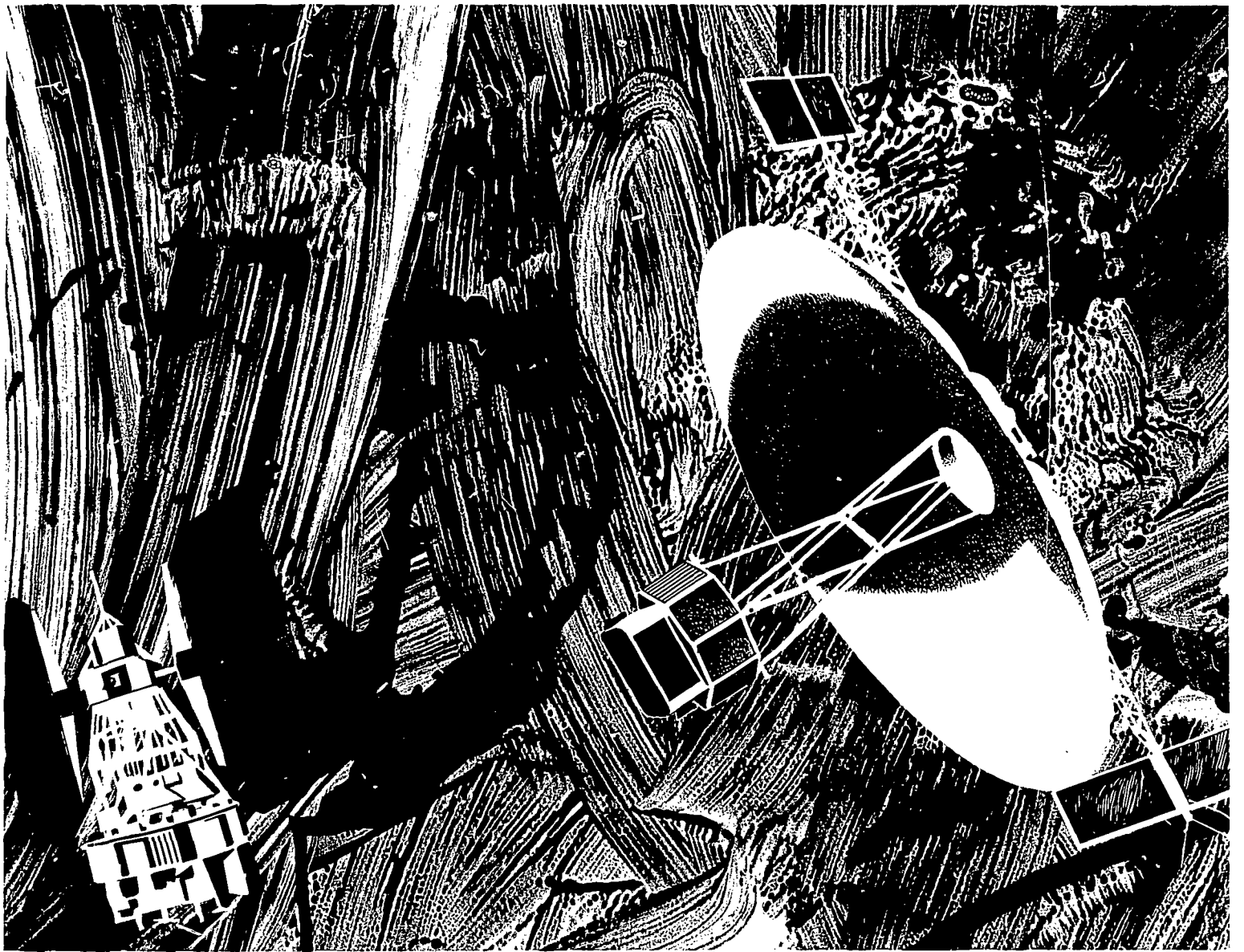

OSSA'S R&D TASKS TOWARD SEVENTIES STRESS SATELLITES FOR SERVING MAN



Interview with Dr. John E. Naugle
Associate Administrator for Space Science and Applications.

Despite NASA budget decreases over recent years, the budget of the Office of Space Science and Applications has continued to increase, with emphasis on applications

By the very scope and spectrum of its tasks NASA's Office of Space Science and Applications (OSSA) will be operating at the forefront of some of the Seventies' major challenges. Basically, our responsibilities span activities centering on four prime functions:

- Selection of the science and applications payloads for both automated and manned missions. We work very closely with the Office of Manned Space Flight to develop the scientific and applications experiments for the Apollo missions and the projected Skylab.
- Development of automated space flight projects for science and applications.
- Execution of cooperative international programs.
- Mission support and launching of small and medium class vehicles (Scout, thrust-augmented Thor Delta, thrust-augmented Thor Agena, and Atlas-Centaur) for both NASA and non-NASA users such as ESSA, COMSAT, and other nations.

Dual Overlay of Responsibilities

From an overview standpoint, these functions translate themselves into a dual overlay of personal responsibilities: first, as a Program Associate Administrator, I'm charged with the management and technical direction of OSSA R&D programs and projects, which involve work in virtually all NASA Centers; and second, from an institutional position I'm assigned the overall management of the Goddard Space Flight Center, the Wallops Station, the Jet Propulsion Laboratory, and the NASA Pasadena Office (see accompanying charts).

Putting the total tasks of the OSSA in context of the climate of the Seventies, we can summarize our foremost challenge as "operating in a balanced mode." I mean balanced



"Over the years the number of competent individuals aware of space opportunities for experiments has grown steadily in the scientific community; yet such opportunities for their participation have steadily declined, in recent years, due to the shrinkage in funding."

from the viewpoint of program objectives tempered by equal consideration to exploration, scientific knowledge and practical application — as prescribed by the President.

In view of the international climate and conditions that prevailed at the start of the last decade, the main thrust of our space efforts was pointed toward exploration. Having acquired a basic lead in space exploration, scientific knowledge, and technology, we can now apply this experience toward the study and solution of looming earthly problems. Before discussing how we are preparing to work on some of these complex problems, I should like to touch on an aspect of national significance in the long run. Apart from the scientific and technological

legacies from the space efforts of the Sixties, we have also acquired a new awareness of the opportunities for scientific experiments in space. Over the years the number of competent individuals aware of space opportunities for experiments has grown steadily in the scientific community; yet such opportunities for their participation have steadily declined, in recent years, due to the shrinkage in funding. Consequently, during the last two to three years we have been able to accommodate only 10% to 15% of the first-class experiments proposed by the scientific community. And this spells the second major managerial challenge for the OSSA for the Seventies: a very tight selection and coupling of missions, people, and experiments.

SCIENCE AND APPLICATIONS IN THE NASA ORGANIZATION

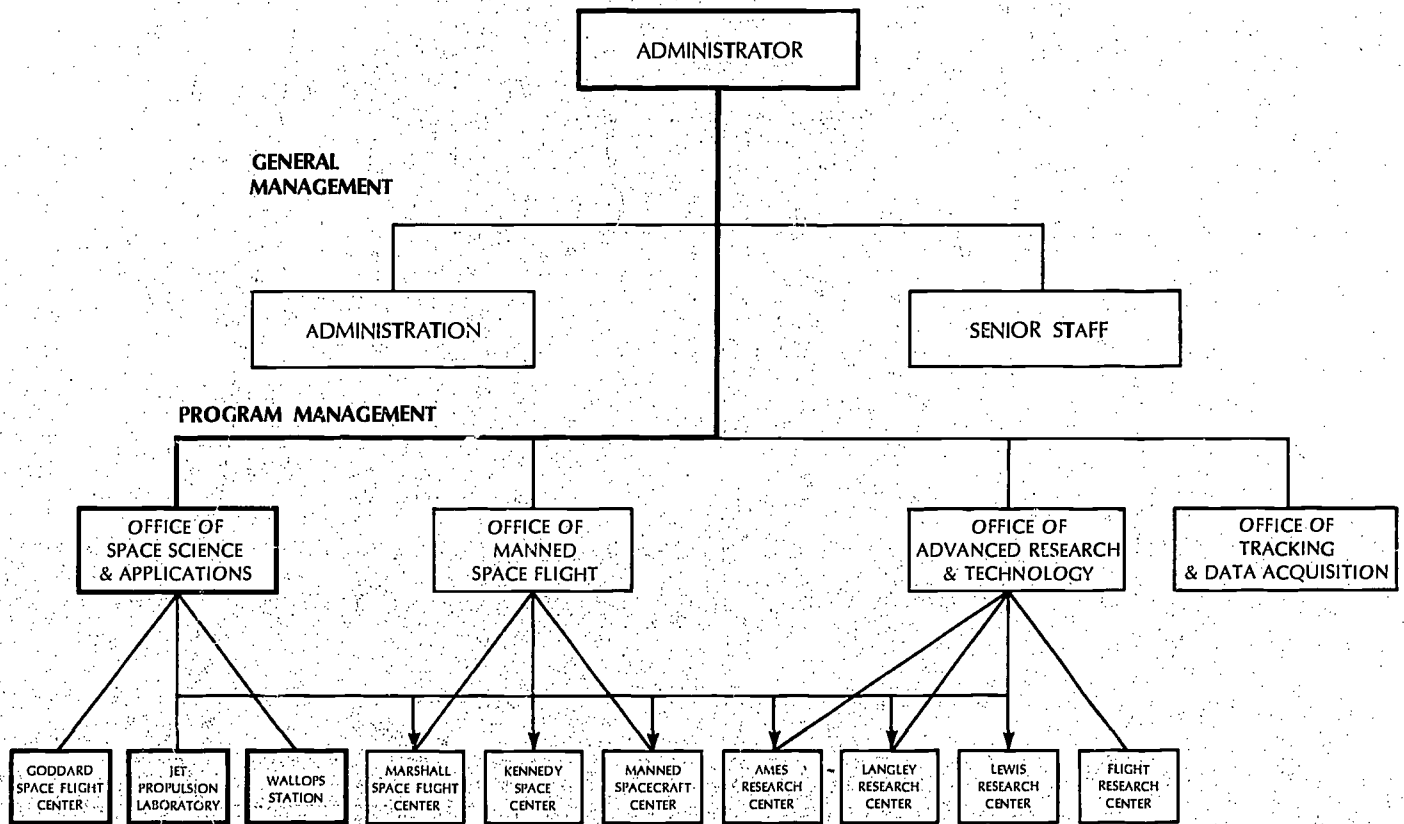

PROJECT SYSTEMS MANAGEMENT

OAO	MM 69	SOUNDING	ATM	LAUNCH	ERS -	PIONEER	SCOUT	AGENA
OGO	MM 71	ROCKETS		SUPPORT	ACFT	BIO-	VIKING	CENTAUR
OSO	MM 73	BARIUM			LRL	SATELLITE	AD/I	ATLAS
TOS		RELEASE			EASEP			TITAN III
NIMBUS		AFCRL			ALSEP			
ATS								
ERTS								
DELTA								
EXPLORERS								
INTERNAT'L								
AGENA								
GEOS								
SOUNDING ROCKETS								

Applications Funding Up

Returning now to the major earthly problems, to the study of which NASA is preparing to apply its resources and experience, we have in FY 1971 allocated to space applications R&D \$69 million over that allocated in 1969. Even though the total NASA budget has decreased over recent years, the OSSA budget has continued to increase as shown below, with the major share of that increase going to applications.

In essence, in the allocation of its scarce resources NASA has emphasized projects which may help solve our problems of immediate priority and has deferred major new starts whose objectives are primarily to gain new scientific knowledge. But obviously, promising scientific projects could not be deferred indefinitely, without mortgaging to some extent the technical progress, the economic vitality, and ultimately the security of this nation.

As reflected in the preceding table of allocations, OSSA R&D programs

are grouped into five major categories of which Space Applications is one. All these categories of efforts are obviously essential to a balanced space program. But for the specific purpose of spotlighting the role of the OSSA with regard to the major and pressing problems of the Earth, I shall confine this discussion to Space Applications.

What are our problems of global dimensions now and for the years ahead, and what challenges do these present in particular to the OSSA?

Problems of Population

In most basic terms, our major global problems are derivatives of the continuing growth of the world's population — imposing ever-growing demands for the basics of life, such as food, water and shelter, as well as for such social needs of civilization as improved means of transportation and communication. And of course the most noxious effect of expanding population and industrialization has been the pollution of the Earth's environ-



"During the last few years we have been able to accommodate only 10 to 15% of the first class experiments proposed by the scientific community."

OFFICE OF SPACE SCIENCE AND APPLICATIONS
FY 1971 Research and Development Budget
Program Summary
(Dollars in Thousands)

	FY 1969	FY 1970	FY 1971
Physics & Astronomy	128,850	111,835	116,000
Lunar & Planetary	87,923	151,013	144,900
Bioscience	37,900	19,670	12,900
Space Applications	98,665	128,400	167,000
Launch Vehicles	99,900	108,000	124,000
TOTAL OSSA R&D	453,238	519,718	565,700

**NATIONAL AERONAUTICS AND SPACE ADMINISTRATION
OFFICE OF SPACE SCIENCE AND APPLICATIONS**

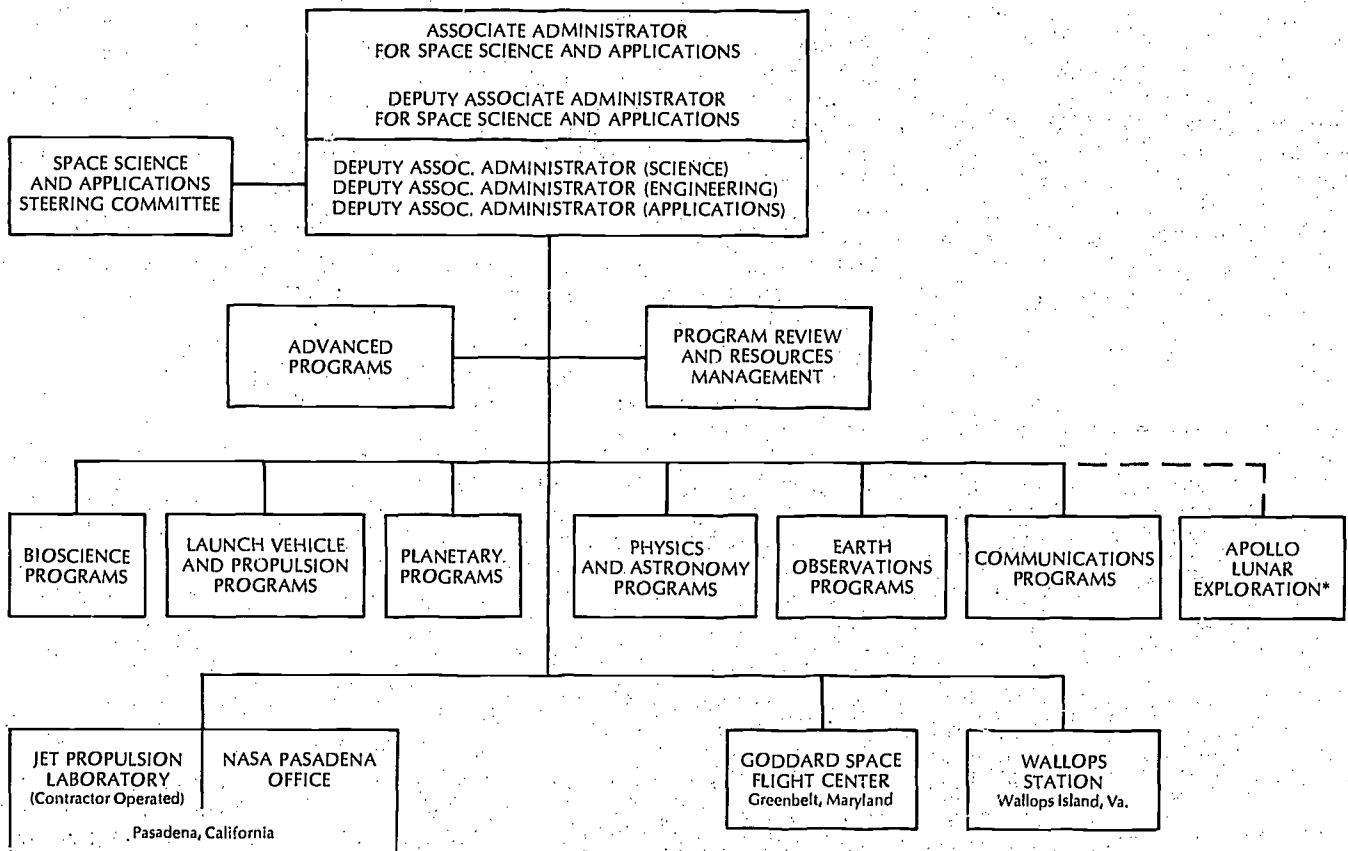

*REPORTS JOINTLY TO OMSF AND OSSA

ment and the effects of this pollution on the mechanics of this environment. Whereas primitive man was once at the mercy of the elements, we are fast approaching the time when both "civilized" man and his environment "the elements" will be at the mercy of his waste. The actions the President has recommended in his message on the environment are essential steps that must be taken now to begin a real attack on this problem. But in the long run, the only way we can really understand and control this situation is on a world-wide basis. If we are to maintain the Earth as a habitable dwelling place for some ten billion human beings in the next century, then we must master the ecology of the planet Earth. The synoptic view that satellite systems give us can help us to understand and develop the Earth's natural and cultural resources and to monitor the status of the environment. Through effective use of our space capabilities we can begin to understand more thoroughly the complex interactions between solar energy, the atmosphere, the oceans and the land — interactions which determine our weather and climate. Man has learned many things about his environment, but exceedingly serious gaps remain. We know, for instance, that there have been major changes in our climate, but we do not know what caused them. We have no idea how stable our present climate is, or how much of a perturbation the environment can tolerate in atmospheric pollution, in ground cover, or in ground water without undergoing catastrophic changes.

These questions spell out a host of scientific and technological tasks for NASA and particularly for the Office of Space Science and Applications (OSSA). Let's now briefly review OSSA's Space Applications Programs, as they relate to some of the major challenges of the Seventies.

Space Applications Programs

Our Space Applications Programs are grouped under two functional categories: Communications Programs and Earth Observations Programs.

Communications Programs: The objective of these programs is to apply space technology and satellite systems, to better serve the national and international needs for communications — with and between earthbound, airborne, and spaceborne terminals — and to continually improve capabilities for terrestrial air and space vehicle navigation and traffic control. These programs also include satellite geodesy, which has as its objective the improvement of our knowledge of the size and shape of the Earth and its gravity field.

The Applications Technology Satellites (ATS) and the Geodetic Earth Orbiting Satellites (GEOS) have been the prime means for attaining the objectives of the Communications Programs. Since the ATS-1 and -3 spacecraft systems have continued to function after most of the planned experiment programs have been completed, we have developed plans to use ATS-1 and -3 for new experiments. As an example, we have approved the proposal by the State of Alaska to conduct educational television and radio broadcast experiments through ATS-1.

ATS-5 was launched in August 1969. However, deployment of the satellite in a spin-stabilized mode about the wrong spin axis prevented the operation of Gravity Gradient Stabilization system. Although we class the mission a failure, we expect to meet many objectives of 7 of the 12 experiments on ATS-5, including the experiments which are important to the design of future navigation and traffic control satellite systems.

In 1969 we completed the design phase of the ATS-F and G project, and shall now proceed with its Phase D, hardware development. However, be-

cause of the need to minimize expenditures, the launch of these satellites has been postponed until 1973 and 1974.

For fiscal year 1971 we also requested and received authorization to initiate the definition and design of an experimental satellite system to improve over-ocean aircraft navigation and traffic control. We shall continue to work jointly with the Federal Aviation Administration and with the European Space Research Organization in this definition and design phase.

Earth Observations Programs:

Here's where we concentrate our efforts toward a better understanding of this planet's environment. There are a number of reasons why we believe we should move aggressively into the fields of Earth observations:

1. Research by user agencies and recommendations of National Academy Summer Study Groups have clearly demonstrated that attainable and significant contributions to the solution of Earth observation problems can be obtained through application of space and astronomical techniques to problems related to solid Earth and ocean physics.

2. Improvements in space technology and verification of our ability to produce suitable space sensor systems have reached the point where such valuable products can be provided to the resource and environmental scientists.

3. Verification of the useful nature of space-acquired remote sensor data has been obtained throughout the resource and environmental scientific community.

4. Ability to use the data is being developed rapidly in the user agencies, the world of commerce, and the academic community.

5. Results from research and development, and experimental satellites in the meteorological program are ex-

ceeding the expectations of the original concepts. We fully expect these advancements to continue to meteorology, and expect a parallel and possibly even more significant history of valuable application and development, and opening of new horizons for improved methods to help us face the critical resources and environmental crises of the nation and the world.

Among the many recent achievements of the Earth Observations Programs I would like to highlight, in particular, three: the results of NIMBUS 3, of TIROS-M, and those of the Multispectral Camera Photography from APOLLO 9.

Probably the most significant achievement of the past calendar year was the successful measurement from space of the vertical distribution of temperature, ozone content, and water vapor content in the atmosphere by sensors installed on NIMBUS 3. Two experimental sensors, the Satellite Infrared Spectrometer (SIRS) and the Infrared Interferometer Spectrometer (IRIS), have demonstrated the feasibility of obtaining atmospheric temperature soundings from space. This new capability, which represents a genuine breakthrough in meteorological technology, will enable us to obtain quantitative data from the entire globe, rather than from the conventional stations—located mostly in the temperate belt of the northern hemisphere—from which we now obtain such soundings of the atmosphere.

The prototype of the next generation of operational meteorological satellites, TIROS-M, or ITOS-1 as it is now known, was successfully launched in January 1970. TIROS-M provides day and night observations of cloud cover, and combines in one spacecraft the ability to provide both a picture of the global cloud cover and a picture of the local cloud cover to stations below the satellite's path. Previously, two

spacecraft were required to provide the same capability.

Another highlight was the multispectral camera photography (S065) experiment on APOLLO 9. In this experiment cameras were flown that were designed to provide the same resolution and cover the same parts of the color spectrum as the television cameras we have planned for the Earth Resources Technology Satellite. The S065 pictures, together with concurrent aircraft pictures, show that at the resolution obtainable from television cameras planned for the Earth Resources Technology Satellite the tonal signatures, combined with sequential coverage, can be used to identify crops, determine their vigor, and estimate their yield.

The major Earth Observations projects are NIMBUS, the Earth Resources Technology Satellite, and the Synchronous Meteorological Satellite. NIMBUS 4 launched successfully on April 8, 1970, is continuing the work of NIMBUS 3. We have two more launches of this versatile meteorological observatory, NIMBUS E and F, scheduled in 1972 and 1973. Those two observatories will explore the use of microwaves to sound the atmosphere, which will enable us to sound through cloud layers. We shall also use NIMBUS E and F, in conjunction with the Applications Technology Satellites F and G, to test the feasibility of data relay and satellite tracking.

We are also proceeding with the development of a Synchronous Meteorological Satellite (SMS), with the launch of the prototype spacecraft scheduled for early 1972. The SMS will provide the capability to achieve continuous observations of selected portions of the Earth's cloud cover.

The Earth Resources Survey Program is progressing toward the launch of the first Earth Resources Technology Satellite, ERTS-A, in 1972, but we still have a lot of work to do. Some

prototype experiments have been conducted through the aircraft program; some Earth-oriented space photography has been obtained through the manned space-flight programs; and an analog of the television camera systems that are planned for ERTS A and B was tested on the S065 experiment on APOLLO 9.

All these data sources and experimental programs have been developed by NASA in close cooperation with the Departments of Agriculture, Interior, Commerce, and Navy. The academic and industrial communities also have been included in this program through direct NASA support and through cooperative programs with the user agencies.

Experience to date with a large variety of data sources and extensive analysis programs indicates that we can, with continuing cooperation of the user agencies, move toward our goal which has been stated in NASA's report to the President's Space Task Group as:

"To establish a capability for responsible management of the Earth resources and human environment."

Academic Lag in Applications

Needless to say, both material and manpower resources are essential to the success of any program. But while material resources can be allocated or shifted between priorities, resources of experienced and competent manpower can hardly be produced on demand. This is another way of saying that to be able to make the most of our space capabilities for service to man, we shall also need in greater numbers scientists, engineers and administrators, who understand the Earth's ecology as well as spacecraft technology and capabilities. For our space science and exploration programs we have in the past and shall continue to engage the best talent in NASA Centers and the academic

community. It is important to involve the scientists in universities because they can feed the newly acquired knowledge directly into the mainstream of our academic life, thus making it possible for us to get new PhD's who have teathed on some of our new programs. Yet, I feel we have not had academic involvement in applications sciences to the same extent as in pure science, and I consider this to be one of our vital needs for the future. I can judge this need from the fact that in inviting proposals for experiments from universities we usually receive about 10 to 15 of purely scientific nature to one or two that are oriented to understanding the basic problems of the ecology of the Earth.

Another good reason for strengthening our academic orientation toward applications is the greater opportunities that will become available later in this decade through the Space Shuttle. We are presently studying ways of delivering and supporting both applications and exploration payloads through the use of the Shuttle. Our studies are aimed at ways of reducing space transportation costs, and of maximizing the results we obtain from the payloads we place in space.

Ways of the World

While we are discussing the role of the academic community in orienting the coming generations of scientists and engineers to the needs and opportunities ahead, I should like to suggest if I may the cultivation of one more attribute in the well-informed and highly enthusiastic youth of today. I feel the academic community is doing a splendid job in imparting technical education to an exceptionally bright generation of budding engineers and scientists. I only wish it were possible for them to have also the benefit of some courses in the "ways of the

outside world" before leaving the ivy-covered halls of academe. For the fact is that knowledge of this nature — which at present is primarily acquired through experience — is essential even prior to beginning the practice of one's profession. We have no lack of competent and imaginative teachers in our academic community, so I shall let them work out the details of such a curriculum. **A**



"Whereas primitive man was once at the mercy of 'the elements', we are fast approaching the time when both 'civilized' man and his environment, the elements, will be at the mercy of his wastes."



COOPERATIVE INTERNATIONAL VENTURES OF 60S FORM BASES FOR BENEFICIAL PROGRAMS OF 70S

Interview with Arnold W. Frutkin
Assistant Administrator for International Affairs

Extensive participation of international scientific community in US space efforts provides prototypes for applications programs oriented to the global needs of man

Cooperation with other nations, in the conduct of aeronautical and space activities, is one of the clearly stated objectives of our charter, as provided by the National Aeronautics and Space Act of 1958. We have been seriously interested in such cooperation, and have devoted considerable time and energy over the last ten years to the development of meaningful working relationships. It has been a rewarding experience in most respects, though disappointing in some others. I want to emphasize first the progress we have made in joint ventures in space.

Cooperatively Funded Projects

Since the start of the Sixties, NASA has entered into nearly 250 agreements for international space projects. These have comprised specific kinds of undertakings with tangible results — not simply meetings and discussions. Such projects have been funded cooperatively by the participants, and not through the export of dollars.

These agreements have been made with some 35 separate countries, while broader programs involve the scientific communities of about 70 countries. The most significant form of cooperative activity has probably been the launching by NASA boosters of satellites developed by other nations. An example of such activity is the \$100 million HELIOS project with Germany. We also solicit proposals for experiments from abroad, to be selected on their merits, for flight in our own satellites. We have participated in over 500 cooperative soundings of the atmosphere by rocket, from sites in all quarters of the world. Right now, some 50 foreign scientists are involved in the analysis of lunar surface samples. We have made it possible for some 50 countries to have direct daily reception of data from our weather satellites, using simple equipment of their own, and we have engaged in



"We have been seriously interested in international cooperation, and have devoted considerable time and energy over the last ten years to the development of meaningful working relationships."

major ground stations in a dozen countries in the experimental testing of communication satellites.

Arrangements exist also for the extensive participation of foreign technicians in the operation of our overseas tracking and data acquisition facilities. The United Kingdom, Canada, Australia, Spain and South Africa actually run stations for us. And lastly, we have provided important international training and information programs. There are some equally significant cooperative projects and undertakings with British, Canadian, French and German agencies.

The total list of cooperative efforts is much too extensive to cover in detail here. The significant aspects of these undertakings are the cost savings, the scientific and technological bene-

fits, the impetus to space research, and the strengthening of working relationships with the world's scientific communities. These are aspects that benefit all the participants and provide incentives for further efforts of international scope.

Now, what can we learn from our experience in the Sixties, to use as guidelines for more rewarding international relationships in our field of endeavor in the Seventies?

We can look at the considerable spectrum and international impact of our joint efforts, and conclude that in the first decade of space exploration we haven't done so badly. Or we can face up to aspects where we haven't been as successful as we could have been, and attempt to correct deficiencies — keeping in mind that success in



"Since the start of the Sixties NASA has entered into nearly 250 agreements for international space projects."

cooperative ventures requires the consent and commitment of at least two partners.

Perhaps we should consider as a major deficiency the fact that we have been only marginally successful in engaging the Soviet Union's interest and participation in cooperative aerospace efforts.

Repeat Invitation to the USSR

In accordance with the express desires of four United States Presidents, and many members of the Congress, NASA has throughout its history sought to engage the Soviet Union in cooperative space ventures. Bilateral agreements for four specific projects resulted from the Dryden-Blagonravov talks of 1962-65. These projects included satellite meteorology, communications, geomagnetic surveying, and space biology and medicine. But these agreements provided solely for coordinated efforts, rather than integrated projects. Regrettably, the progress achieved under these limited agreements has been disappointing. A great many other U.S. initiatives over the years have not gained any response from the Soviet side.

Over the past months, former NASA Administrator, Dr. Thomas O. Paine, wrote a new series of letters to President Keldysh and Academician Blagonravov of the Soviet Academy of Sciences, proposing new initiatives in space cooperation. These letters invited Soviet scientists to:

- Propose experiments to fly on our spacecraft.
- Use the laser reflector left on the Moon by the Apollo 11 astronauts.
- Participate in the analysis of lunar surface material.
- Attend a conference on the NASA Viking Mars mission.
- Discuss compatible docking arrangements in space.

In addition, Dr. Paine offered to

discuss the coordination of our respective planetary programs, and reiterated our readiness to meet to consider any possibilities for cooperation between our nations.

The Soviet Response

President Keldysh replied, agreeing that Soviet-American cooperation in space "bears a limited character at the present time and there is need for its further development". He accepted Dr. Paine's suggestion for a meeting on this question, but deferred its time and place. He declined our specific invitation of Soviet proposals for experiments aboard NASA planetary probes, advocating instead, a relationship in which NASA and the Soviet Academy would coordinate "planetary goals" and "exchange results" of unmanned planetary investigations.

In September 1970, President Keldysh indicated an interest in taking up Dr. Paine's suggestion that we explore compatible docking arrangements for Soviet and NASA spacecraft. It was then agreed that five NASA representatives should meet with their Soviet counterparts on October 26-27 for preliminary discussions.*

Another deficiency in the space efforts of the Sixties was the absence of foreign participation in the development of such major space items as the Saturn vehicle and the Apollo spacecraft. Undoubtedly, other countries did not feel equipped yet to contribute to these demanding activities, and our national commitment to lunar landing, within the decade, left very little leeway for them to catch up within the time frames we had set for ourselves. However, just as in the case of the Soviet cooperation "gap", we



"It is not difficult to envisage in gross form the types of arrangements appropriate to important cooperative ventures. We can foresee, for example, participation in clearly separable tasks with well-defined interfaces, and participation with NASA in the development of integral systems or subsystems."

*An agreement for compatible docking arrangements was signed in Moscow on October 28, 1970.

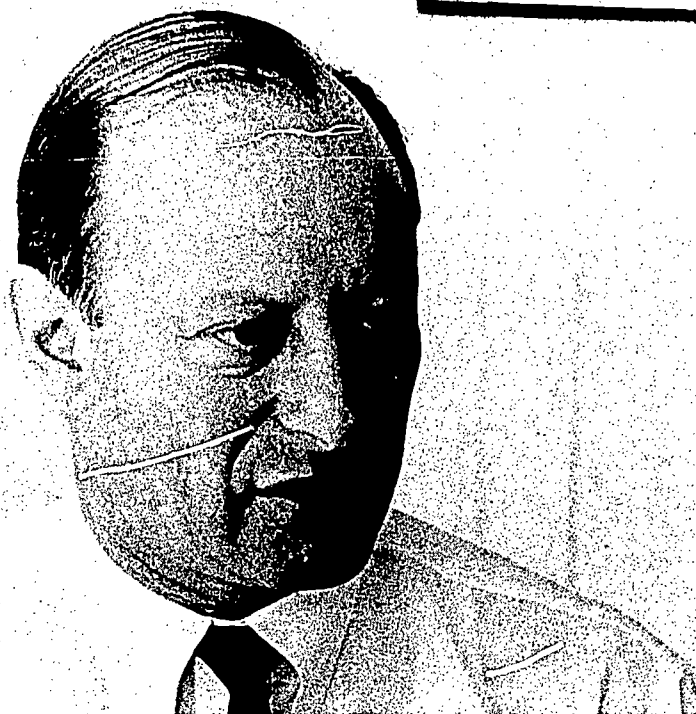

"We are hopeful that the benefits of joint space efforts will enhance the healthy growth of international participation, and motivate the Soviet Union also to enter into substantive cooperation."

are now taking definite steps to invite international participation in our major hardware programs of the future.

Dr. Paine's Briefing Tour

At President Nixon's request, in October 1969 Dr. Paine visited the major European capitols with a specific mission: to inform ministerial and space agency officials, including senior officials of the European Space Conference, of the detailed U.S. plans for space exploration and utilization over the next two decades.

We made a similar brief trip to

Canada in December 1969, and another in the early Spring of 1970 to Australia and Japan. In all of these countries, Dr. Paine described the principal elements of our future space programs — the balanced science and application programs, the reusable Space Shuttle, the multi-purpose Space Station, and the advanced nuclear stage — as recommended in the report of the President's Space Task Group. In each of these countries we invited careful study of our plans so that each nation could assess the implications of our proposed future advances for their own planning, so they could determine what interest they

might have in constructive participation in these programs.

To support this initiative and help potential participants acquire the information they need to determine the extent and nature of their interests, we have already taken several additional concrete steps:

(1) In October 1969, NASA convened in Washington a conference of industrial firms to critique concepts for the Space Shuttle and to lay out design considerations for the next steps in the program to develop the Shuttle. At our invitation, some forty-three foreign participants and observers attended from Germany, France, the United Kingdom, the Netherlands, Canada, Sweden, and Italy, as well as the European Launcher Development Organization.

(2) As a next step we invited representatives of the European Space Conference, the European Space Research Organization (ESRO), the European Launcher Development Organization (ELDO), and many of the national agencies with which we deal bilaterally (including Canada, Australia, Japan, Brazil, India and others) to attend a quarterly review of NASA space station studies in March. Seventeen countries were represented.

(3) We briefed several hundred European officials, scientists, and industrial people in Europe, in June, July and September 1970, on the Shuttle and Space Station programs.

(4) Further arrangements for information exchange in this early period of planning and study for the new programs of the 1970's are being made so that other interested nations can both observe and contribute. For instance, foreign participation was invited, and will be next year, in elaborate summer studies of requirements for the future Space Station.

(5) ESRO and ELDO have both set up full-time liaison offices with NASA in Washington, and have provided

them representation on our supporting technology steering committees for the Space Station and the Space Shuttle. On their side, the European Space Conference has already voted funds to the extent of several million dollars for early studies of possible contributions to the post-Apollo program.

The Way Is Open

The degree to which other nations will decide to participate in the major developmental programs of the future depends on decisions that only they can make.

Certainly, many have the technical capacity and financial strength to participate. Only if they do so can there be a fully equitable sharing of both the benefits and the costs of space exploration and utilization. At present all of the "third" countries together spend roughly \$300 million a year on space. This is an order of magnitude less than the space expenditures of the United States and, we believe, of the Soviet Union.

Should other industrialized countries decide to allocate larger amounts of their resources to cooperative programs in space, the way will be open for their participation in the development of the large-scale systems. We believe these systems are going to pay important scientific and technological dividends in the future. We also believe that the Shuttle and the Space Station will reduce the costs and totally change the manner of conducting space experiments in both science and applications. This will come about as these facilities make it easier for men to work in space, giving us capabilities for servicing and repairing space systems, and even permitting us to retrieve and reprogram experiments.

Decisions Take Time

It is not too early to discuss in

detail such benefits, nor is it too early to lay the basic foundations to future cooperation on such programs. We do recognize that decisions of this magnitude cannot be made overnight, without the development of adequate information bases. It is for this reason that we have, invited our colleagues from other countries to attend our internal management sessions, study reviews and conferences — even to establish permanent liaison offices in Washington. Their closer orientation to these forthcoming projects during the planning phase of this year should make it easier to organize the mechanisms of their eventual participation.

These are, of course, decisions to be made by them, and not by NASA. We certainly want to provide maximum scope for the making of such decisions, and here timing is important. That is, with the passage of time we shall be approaching commitment to design and development, and shall have less leeway ourselves.

Models For Cooperation Exist

It is not too difficult to envisage in gross form the types of mechanisms or arrangements that may be appropriate to such important cooperative ventures; we already have had some ten years of experience with joint efforts, though on smaller programs. We can foresee, for example, two basic types of cooperative effort: (1) participation in clearly separable tasks with well-defined interfaces, and (2) participation with NASA in the development of integral systems or subsystems.

In the first instance, our established relationships would apply through agency-level agreements, employing joint working groups to coordinate the tasks and assure the compatibility of interfaces.

In the second case, we would need to arrange, again through agency agreements, for a closer industry-to-in-

dusty interface, possibly on the basis of consortiums of companies from both sides. Since NASA would very likely have the major responsibility, the prime contractor would certainly have to be American. Foreign governments would fund their subcontractor participation. And to preserve manager effectiveness, the U.S. prime would have a voice in the release of foreign funds to the subcontractors.

Even though it is still quite early for detailed discussions, we are pleased to see some evidence of European focus on the Shuttle and Space Station programs. As I indicated, ESRO is already funding studies of a Space Station module and ELDO is funding studies of an orbit-to-orbit space tug, which would operate with the Shuttle. We are very hopeful that these preliminary interests will be followed up and develop into participation of real significance. We are equally hopeful that the benefits of joint space efforts will enhance the healthy growth of international participation, and motivate the Soviet Union also to enter into substantive cooperation.

Sharing Support and Benefits

In concluding this brief review of international space efforts, I can think of no words which summarize our aspirations better than the assertions made earlier this year by President Nixon:

"... the United States will take positive, concrete steps toward internationalizing man's epic venture into space — an adventure that belongs not to one nation but to all mankind. I believe that both the adventures and the applications of space missions should be shared by all peoples. Our progress will be faster and our accomplishments greater if nations will join together in this effort, both in contributing the resources and in enjoying the benefits".

INTERNATIONAL PROGRAM SUMMARY

The 1958 legislation creating NASA provided that "the aeronautical and space activities of the United States shall be conducted so as to contribute materially to ... cooperation by the United States with other nations and groups of nations in work done pursuant to this act and in the peaceful application of the results thereof." NASA's international programs, undertaken to implement this directive, can be categorized in three principal areas: space sciences, space applications, and the ground support of space operations. (It should be noted that in these cooperative programs, it is a cardinal principle that each side funds its own participation.)

What follows is a brief, selective summary description of these programs.

I. SPACE SCIENCES

Cooperative satellite projects are a major element of international space science programs. In these projects, the foreign participant contributes the satellite while NASA contributes the launching. NASA in effect gets a free satellite, while the cooperating partner gets a free launching. To date there have been 12 such cooperative launchings of spacecraft built by the United Kingdom, Canada, France, Italy and Germany, as well as by the European Space Research Organization (ESRO).

The satellites launched in 1969 include:

- ISIS-A, a Canadian ionospheric research satellite, and
- Azur, a German radiation belt experiment.

Ten additional cooperative satellite projects have been agreed upon, and there are prospects for the further continuation and growth of coopera-

tive satellite programs. It is anticipated that Spain, Sweden and possibly others will be participating in the future. New projects are also being planned with present partners.

The U.S. and Germany agreed last year to the most ambitious cooperative spacecraft effort yet undertaken. In this project, called HELIOS, two German spacecraft, carrying seven German and three U.S. experiments, will be launched by NASA to make physical measurements within about 28,000,000 miles from the sun, closer than any spacecraft has flown before. HELIOS will complement the NASA Pioneer series of spacecraft in providing total solar system coverage. Of the total project cost, estimated to exceed \$100,000,000, Germany will bear the major portion.

In addition to cooperative satellites, NASA also solicits foreign proposals for experiments to be flown on NASA satellites. Twenty-two such experiments from France, the U.K., Italy, the Netherlands and Switzerland have been selected on their merits through competition with U.S. and other proposals. Of these, 17 have been flown to date. Financial support was provided by the foreign sponsors. Through this program, foreign scientists have opportunities to participate in useful flight research, while NASA gains access to outstanding space science capabilities in the international community. The flight opportunity is made available at no cost to the foreign cooperators who, in turn, make their experiments available at no cost to NASA.

The launching of foreign scientific spacecraft on a cost-reimbursable basis is an international activity of growing importance. Already two ESRO satellites have been successfully orbited under such arrangements and four more are planned for the future. Dis-

cussions are also underway with other nations.

The program to analyze lunar samples returned in the Apollo program now includes 55 approved Principal Investigators from 16 countries—Australia, Belgium, Canada, Czechoslovakia, Finland, Germany, India, Italy, Japan, Korea, Norway, South Africa, Spain, Switzerland and the U.K. Thus nations around the world are afforded the opportunity to share, in a scientifically significant way, in one of man's truly great endeavors. These investigators, selected on the merits of their proposals and with no U.S. financial support, are performing a full range of physical, chemical, mineralogical and biological experiments on the lunar samples, along with their 139 American colleagues. Other important international participation in Apollo 11 included:

- A Swiss solar wind experiment placed on the lunar surface and later retrieved by the astronauts.

- A laser reflector left on the lunar surface and announced as available to all countries (and already in use by France).

Sounding rocket programs represent a broad area of international cooperation, some nineteen countries having joined with NASA in projects of mutual interest. Because of the low costs of sounding rocket work, countries without the resources for satellite projects are able to participate directly in valid scientific space flight projects. In addition, the small launching facilities developed in such countries as Brazil, India, Argentina and Pakistan have been available to NASA sounding rocket programs that have required special launch locations for research into polar, auroral and equatorial phenomena. More than half of NASA's total sounding rocket effort is in collaboration with foreign partners, with launchings in 14 different countries.

More than 40 countries have been involved in a wide range of cooperative ground-based observations, as distinguished from flight projects. Scientists abroad have been able to carry out such observations in support of orbiting satellite projects in such fields as ionospheric studies and geodesy. Many of these complementary ground activities have actually been necessary to achieve flight program objectives.

A variety of research and training opportunities for foreign scientists and engineers in space-related science and engineering at U.S. universities and NASA centers are available and have so far involved more than 1,000 individuals from some 40 countries. In many cases the participants in these programs have returned to their countries to serve as the nucleus around which national space organizations and programs have developed.

II. SPACE APPLICATIONS

Experimental communications satellites have for the past decade been a major element in international collaboration. In the early Relay, Telstar and Syncom experiments a dozen countries built ground terminals at their own expense to work with NASA in testing these satellites. From this beginning has evolved the 74-member INTELSAT consortium which has greatly expanded telecommunications capacity internationally, reduced costs substantially, and provided real-time TV coverage in large portions of the globe. NASA also provides reimbursable launchings for foreign national communications satellites; U.K. and Canada satellites will be the first.

Under a major new agreement with India, NASA will make available its ATS-F satellite for a one-year Indian instructional television experiment. Villages equipped with augmented TV receivers will receive programs on pop-

ulation control and agricultural productivity while the technical feasibility of satellite TV direct broadcast is tested in an operational setting.

NASA's efforts in the weather satellite and rocket field have been strongly influenced by international concerns. Meteorological satellites now routinely deployed have been designed so that nations everywhere can use inexpensive (or easy-to-build) Automatic Picture Transmission (APT) sets to obtain daily weather prospects directly from U.S. satellites. These sets are in use in some 50 countries. And regular, coordinated weather rocket soundings on a North-South line in the Western Hemisphere have been undertaken in an Inter-American Experimental Meteorological Rocket Network (EXAMET-NET). Since inception in 1966 our partners in Argentina and Brazil have launched more than 100 rockets, synchronized with similar launchings from various U.S. sites.

NASA is also engaged with France in a cooperative meteorological satellite and balloon project, EOLE, to test the feasibility of such a system for tracking global winds. Balloon and satellite launchings are scheduled for late this year. Cooperation in an advanced synchronous weather satellite project is under discussion with France.

Earth Resources Surveys (ERS). Pre-satellite emphasis in the ERS area has been on actions to inform the international community about the evolving U.S. program, to provide orientation and training, and mount aircraft-based programs in preparation for the use of later satellite data. Cooperative aircraft programs with Brazil and Mexico are proceeding and remote sensing techniques are being made available to India for the identification of areas of coconut palm blight in Kerala state. In addition, the U.S. is cooperating with Canada in the devel-

opment of sensors, NASA's fellowship program is being extended to cover remote sensing-related disciplines, and briefings have been arranged for international groups, such as the UN Outer Space Committee.

III. SPACE OPERATIONS SUPPORT

The tasks of tracking, communicating with and acquiring data from the multitude of NASA's manned and automated spacecraft have required the extensive and intimate participation of 21 countries. Some 25 stations around the world are at present operated with active support, and often direct staffing, by nationals of the host countries. In several locations, the costs of operating the stations are borne by the host countries. NASA maintains close ties with the ESRO and French tracking networks, and specific project support exchange arrangements are increasing in number.

Extensive operational arrangements have been made with dozens of countries in Africa, Asia and South America for the staging and overflight of U.S. aircraft in conjunction with contingency assistance operations for the Mercury, Gemini and Apollo programs.

COOPERATIVE INTERNATIONAL AERONAUTICS RESEARCH

France

NASA and ONERA, the French civilian aeronautics research agency, are conducting a cooperative wind tunnel research project to test rigid and flexible tilt rotors for V/STOL aircraft. The rotors are being tested with various distributions of twist and camber, simulating the effect of aeroelasticity on blade shape. This research will contribute to rotor-prop design state-of-the-art. High speed tests

(approximately 200–500 knots) are being conducted in ONERA's S-1 wind tunnel, and low speed tests (0–200 knots) in the Ames 40' x 80' tunnel. NASA is providing the rotors. ONERA's conducting the S-1 wind tunnel tests at no charge to NASA. Data resulting from the program will be shared.

NASA has contracted with LTV (subcontract with the Giravions-Dorand Company of France) to look into the most promising applications of the Jet-Flap Rotor, which was designed and developed by Giravions-Dorand.

In 1966 NASA contracted for 20 hours of flight time on the Breguet 941 STOL aircraft. This aircraft was recently used by Eastern and American Airlines to study the possible application of a STOL aircraft for commercial short-haul transport use in the Northeast Corridor.

Germany

NASA and BMBW (German Ministry for Education and Sciences) have agreed to two cooperative efforts related to the Do-31 aircraft, a unique advanced Jet V/STOL transport. In the first, the stability, control, and handling qualities of the Do-31 have been studied during landing, transition and descent phases of flight on the NASA/Ames 60-of-freedom simulator. In the second, NASA pilots will fly the Do-31 for approximately 12½ hours. The purpose of the flight program is to examine the handling qualities and the performance limitations of the Do-31 under various VTOL and STOL descent and ascent conditions. Terminal area operating problems of the aircraft will also be studied. NASA's contribution is to take the form of a \$700,000 contract with Dornier, the Do-31 developer. Do-31 development was funded by the German Government at

NASA INTERNATIONAL ACTIVITIES SUMMARY CUMULATIVE TO JANUARY 1970	COOPERATIVE PROJECTS											PERSONNEL EXCHANGES				TRAINING AT CENTERS	TRACKING & DATA ACQUISITION STATIONS		
	FLIGHT PROJECTS					GROUND-BASED PROJECTS FOR:						RESIDENT RESEARCH ASSOCIATESHIPS	INTERNATIONAL FELLOWSHIPS	TRAINING AT CENTERS					
	SATELLITES	EXPERIMENTS ON NASA SATELLITES	ROCKETS	LUNAR SAMPLE ANALYSIS	IONOSPHERIC SATELLITES	GEODETIC SATELLITES	METEOROLOGICAL SATELLITES	COMMUNICATION SATELLITES	EARTH RESOURCES PROGRAMS	AERONAUTICS									
ARGENTINA																			
AUSTRALIA																			
AUSTRIA																			
BAHRAIN																			
BELGIUM																			
BOLIVIA																			
BRAZIL																			
BURMA																			
CANADA																			
CEYLON																			
CHAD																			
CHILE																			
CHINA, REPUBLIC OF																			
COLOMBIA																			
COSTA RICA																			
CYPRUS																			
CZECHOSLOVAKIA																			
DENMARK																			
GREENLAND																			
ECUADOR																			
EL SALVADOR																			
ETHIOPIA																			
ESRO 1/																			
FINLAND																			
FRANCE																			
GUADELOUPE																			
TAHITI																			
GERMANY, FED. REP. OF																			
GHANA																			
GREECE																			
HUNGARY																			
ICELAND																			
INDIA																			
INDONESIA																			
IRAN																			
IRAQ																			
IRELAND																			
ISRAEL																			
ITALY																			
JAMAICA																			
JAPAN																			
KENYA																			
KOREA																			
MADAGASCAR																			
MALAYSIA																			
MALDIVE ISLANDS																			
MAURITIUS																			
MEXICO																			
NETHERLANDS																			

NASA INTERNATIONAL ACTIVITIES SUMMARY CUMULATIVE TO JANUARY 1970	COOPERATIVE PROJECTS											PERSONNEL EXCHANGES				TRAINING AT CENTERS	TRACKING & DATA ACQUISITION STATIONS		
	FLIGHT PROJECTS					GROUND-BASED PROJECTS FOR:						RESIDENT RESEARCH ASSOCIATESHIPS	INTERNATIONAL FELLOWSHIPS	TRAINING AT CENTERS					
	SATELLITES	EXPERIMENTS ON NASA SATELLITES	ROCKETS	LUNAR SAMPLE ANALYSIS	IONOSPHERIC SATELLITES	GEODETIC SATELLITES	METEOROLOGICAL SATELLITES	COMMUNICATION SATELLITES	EARTH RESOURCES PROGRAMS	AERONAUTICS									
NEW ZEALAND																			
NIGERIA																			
NORWAY																			
PAKISTAN																			
PERU																			
PHILIPPINES																			
POLAND																			
PORTUGAL																			
ANGOLA																			
MOZAMBIQUE																			
QATAR																			
SENEGAL																			
SINGAPORE																			
SOUTH AFRICA																			
SOUTHERN RHODESIA																			
SOUTHERN YEMEN																			
SPAIN																			
SUDAN																			
SWEDEN																			
SWITZERLAND																			
TANZANIA																			
THAILAND																			
TURKEY																			
UNITED ARAB REPUBLIC																			
UNITED KINGDOM																			
ANTIGUA																			
ASCENSION ISLAND																			
BERMUDA																			
CANTON ISLAND																			
FIJI ISLANDS																			
GRAND BAHAMA																			
HONG KONG																			
URUGUAY																			
USSR 2/																			
VENEZUELA																			
ZAMBIA																			
TOTAL PARTICIPATION	6	5	1 ^{1/2}	16	42	14	66	13	3	4	37	20	21	26					
	● CURRENT ○ COMPLETED PROJECT OR DISCONTINUED ACTIVITY																		

1/ EUROPEAN SPACE RESEARCH ORGANIZATION (BELGIUM, DENMARK, FED. REP. OF GERMANY, FRANCE, ITALY, NETHERLANDS, SPAIN, SWEDEN, SWITZERLAND, UNITED KINGDOM).

2/ AGREEMENTS PROVIDE FOR:

- (1) COOPERATIVE COMMUNICATIONS SATELLITE EXPERIMENTS VIA ECHO,
- (2) COORDINATED LAUNCHINGS OF NATIONAL METEOROLOGICAL SATELLITES AND DATA EXCHANGE,
- (3) LAUNCHINGS OF NATIONAL SATELLITES EQUIPPED FOR MAGNETIC MEASUREMENTS AND EXCHANGE OF PROCESSED DATA, AND
- (4) JOINT REVIEW OF SPACE BIOLOGY AND MEDICINE.

3/ INCLUDES EARLY CORRELATED GROUND DATA AND CURRENT APT USE.

4/ FOREIGN VISITORS TO NASA FACILITIES.

5/ INCLUDES ELECTRONIC AND OPTICAL (SAO) STATIONS.

a cost of over \$40 million. The present flight test program is being funded by the Germans at a level of approximately \$6 million.

United Kingdom

NASA and the U.K. Ministry of Technology (Mintech) are cooperating in testing the British **Hunting-126 Jet-Flap STOL** aircraft in the Ames 40' x 80' wind tunnel.

NASA and Mintech cooperated in conducting runway tire traction tests at Wallops Station in June 1968. For these studies the British provided a Heavy Load Friction Trailer and associated equipment. Follow-up tests as an extension of this program were conducted in the U.K. during the summer of 1969.

The University of Southampton's Institute of Sound and Vibration Research is one of the foremost research laboratories in the world on aircraft noise problems. NASA has contracted with the Institute for noise research and two Langley engineers are pursuing graduate level research at the University.

In 1966, Defense Dept., transferred to NASA two Hawker-Siddeley P-1127 aircraft for NASA to study the vectored thrust VTOL characteristics of the aircraft under visual and simulated IFR conditions. This program is to extend until 1971 with the intention of accumulating about 125 flight hours.

In 1966 and 1967 the then Ministry of Aviation (now part of Mintech) and NASA cooperated in conducting research on disturbances associated with severe thunderstorms, mountain waves, and tropical storms. Both British and U.S. aircraft were used.

Canada

NASA and the Canadian aeronautical research and development authori-

ties are conducting a wind tunnel research project to study the "augmentor wing" concept, a promising wing configuration for STOL aircraft that originated with the De Havilland Company of Canada. A second phase of this project, involving the testing of the concept on a small research vehicle, is presently under discussion. 

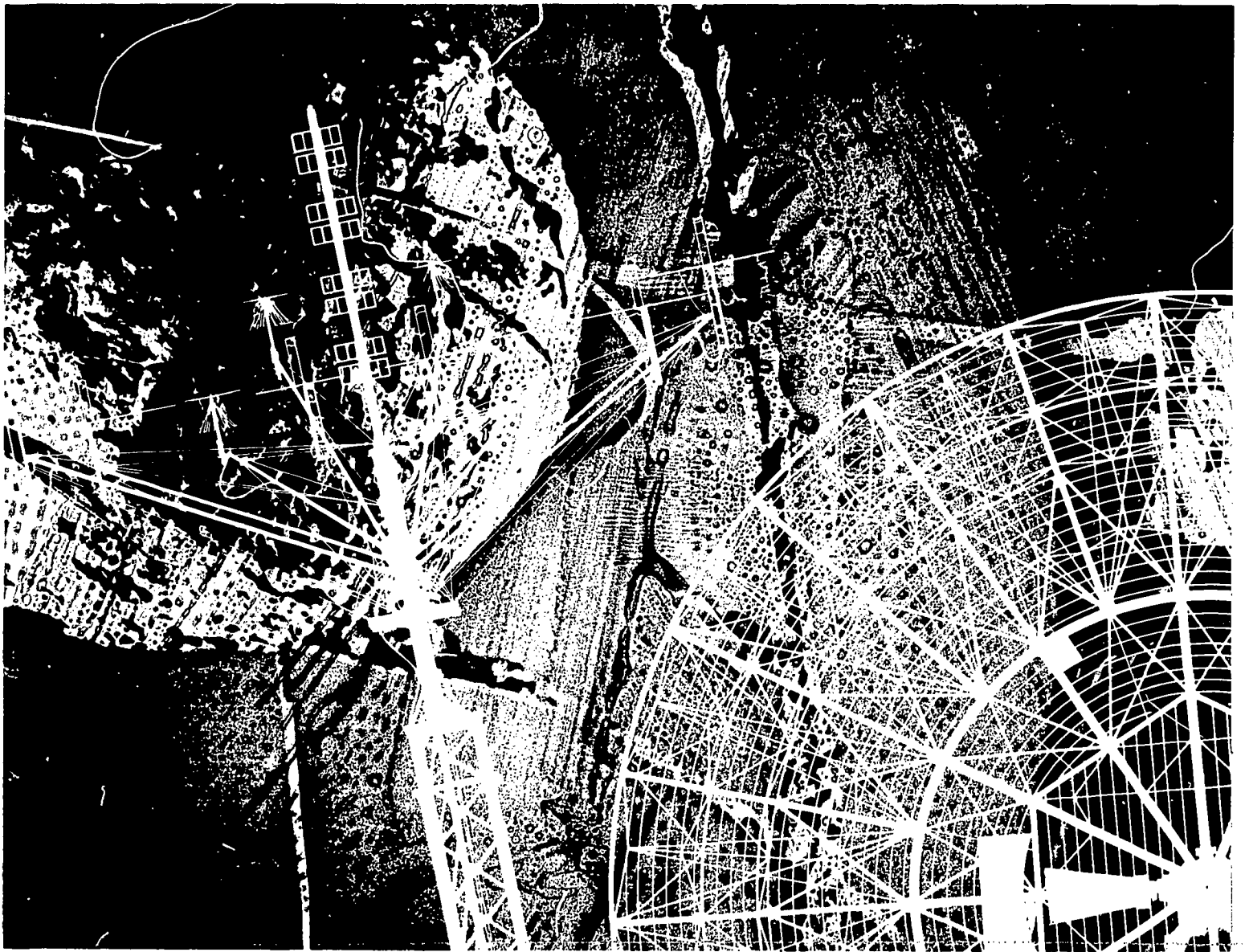

OFFICE OF TRACKING & DATA ACQUISITION MAINTAINS LIFELINES TO SPACE MISSIONS



Interview with H. R. Brockett
Deputy Associate Administrator for Tracking and Data Acquisition

NASA's three specialized communications networks around the world provide the vital links between Earth and spacecraft, to render mission support and gather space data

NASA's Office of Tracking and Data Acquisition is in business primarily to perform a support function. We don't operate to conduct experiments, but conduct experiments only to improve our operations. And in the process of providing the vital communications link for complex space missions we do our best not to contribute to complexity and become "a part of the problem."

Tracking and Data Acquisition techniques have come of age with the evolution of the space program. In Project Mercury we had a flight controller at each of our 16 ground stations; we now have centralized mission control from the Manned Spacecraft Center in Houston. Also, whereas earlier we could only depend on sometimes-reliable High Frequency communications with our distant tracking stations, we now have a combination of several more reliable modes of communication available. With the operational capability provided by the Intelsat II global communication satellites system (January, 1967), we have had satellite, cable, or a combination of both modes of communications available for the Apollo missions. Also, while we were able to maintain contact with the Mercury spacecraft, which was in low Earth orbit, for only 15% of mission duration, now once the Apollo spacecraft reaches an altitude of about 8000 miles we are able to cover these missions 100%. As evidenced during the Apollo 13 mission, continuous coverage of mission progress may provide a life-line out of contingencies. This type of experience will figure in our consideration of data relay stations which I will discuss later.

A first-order breakdown of the functions of the Office of Tracking and Data Acquisition is reflected in Fig. 1, and a breakdown of our FY 1971 budget request is illustrated in pie-chart form in Fig. 2. As implied by the apportionment of funding in this



"Nothing in the universe is in a static state, therefore we need to observe and record changing phenomena over extended periods, in order to determine trends."

chart, network operations constitute the major sector of our current activities, and the principal activities within this area are the operation of three major tracking and data acquisition networks. These networks are operated to meet the needs of the three basic classes of NASA flight missions. Thus we have: (a) the Manned Space Flight Network which, of course, supports the Manned Flight Program; (b) the Satellite Network which supports unmanned scientific and applications satellites; and (c) the Deep Space Network which supports unmanned lunar and planetary missions.

Manned Flight Network

This network consists of 12 land-based stations located between plus or

minus 32° latitude, and an instrumented ship and four aircraft for covering special portions of manned missions. Because of the visible role of this network in manned missions, its function is in general well understood. The many years of experience gained during the support of the Mercury, Gemini, and early Apollo missions contributed greatly to the manned exploration of the moon. In the process, from lift-off to splashdown the network provided the means for the world to share the sounds and sights of man's epic journey beyond the Earth.

This network is currently supporting the Apollo Lunar Surface Experiments Package (ALSEP) left on the moon's surface by the Apollo 12 astronauts. All the ALSEP data, now

**FUNCTIONS
OF
NASA OFFICE OF TRACKING AND DATA ACQUISITION**

Development, installation & operation
of
Instrumentation, equipment, systems & facilities
to
Acquire, record, process & transmit
Operational & scientific data
for
NASA programs

Management of NASA's global communications network (NASCOM)

Coordination & management of NASA-wide automated data processing

Support of NASA's administrative communications network

Frequency management for NASA

Fig. 1

**OTDA R&D BUDGET REQUEST
FISCAL YEAR 1971
TOTAL \$298 MILLION**

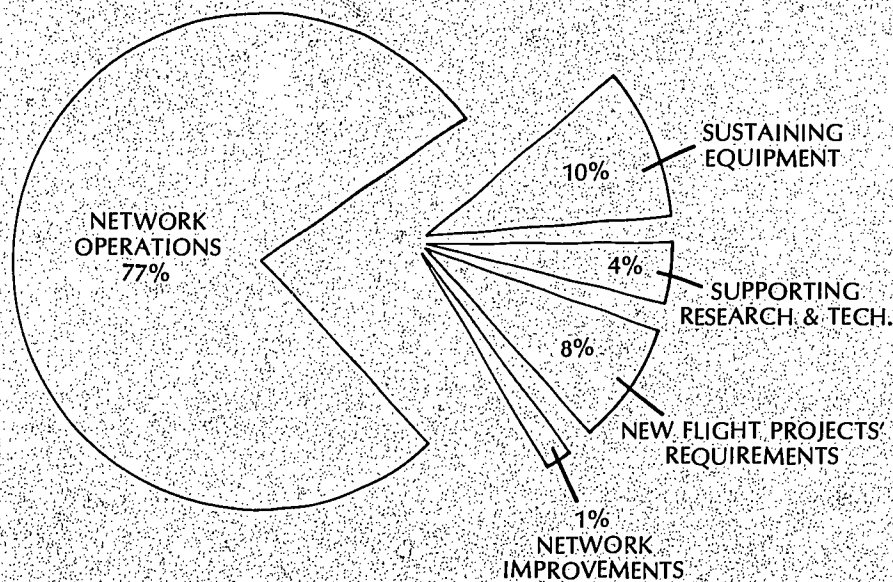

Fig. 2

transmitted from the moon 24-hours per day, will continue to be recorded over the entire two-year lifetime of the experiments.

The network also serves to support a considerable number of unmanned missions of NASA and other government agencies through selected stations; it provides support also to private industry – COMSAT – during the early launch phase of its satellites.

Satellite Network

This network consists of facilities at 10 United States and foreign locations; we consider this as our workhorse network because it is currently supporting close to 50 active satellites. The Goddard Space Flight Center, at Greenbelt, Maryland is the nerve center for this network. The support of this network extends to all of the unmanned Applications satellites and Scientific satellites of NASA and ESSA (Environmental Science Services Administration), the scientific and research satellites of various DOD agencies, and the satellites of cooperative programs with other countries. The network provides support also to private industry – COMSAT.

In addition to performing its normal support functions, the Satellite Network is at times called upon to cope with various mission exigencies. The Orbiting Solar Observatory (OSO-6) and the Applications Technology Satellite (ATS-5), both launched last year, were provided such support – through the network's near-real-time command capability. As a result the scientific data return was increased significantly from the OSO-6 mission, and a probable mission failure was averted in the case of the ATS-5.

This network will continue to support, through FY 1971, many of the satellites presently in operation, as well as ten new spacecraft scheduled for launch in this period. We shall

continue to make adjustments in support priorities and make greater use of existing equipment to meet the projected workload. And to improve the utilization of existing equipment, in the Satellite Network, we are planning to incorporate Station Technical Operations Control (STOC) consoles, which were deferred by funding constraints in prior years. The STOC system will augment network capability by centralizing many routine station functions and allowing rapid check-out of electronic systems; it will also permit the station equipment to be made available more quickly to support successive satellite passes. During this Fiscal Year we shall also complete most of the network augmentation required for the Earth Resources Technology Satellite (ERTS). This includes the procurement of control center computer peripherals, display and control equipment, and wideband recorders at the stations, to handle both Pulse Code Modulation and video signals.

Requirements for gathering and processing satellite data have continued to increase steadily with newer applications. As a result, the network has reached the point where it has the capacity to support only a portion of the spacecraft passes, and a high level of equipment reliability has become essential. Many of the electronic systems at the stations are six or more years old, and they have been operating continuously since they were installed. Consequently, we are now approaching a common dilemma — that of the man who not only needs to spend more and more time and money to keep his vintage car operable, but also has difficulty finding replacement parts for it.

Regarding the need to gather satellite data over extended spans of time, we are sometimes asked why it is necessary to continue gathering the "same" data, over and over, for

months or years. The answer is that the data being gathered are seldom the same. Nothing in the universe is in a static state, and we need to observe and record changing phenomena over extended periods, in order to determine trends.

Deep Space Network

NASA's extremely long-distance missions, the planetary missions, are supported by this network which together with the Manned Space Flight Network supports also the Apollo missions.

This network consists of ground stations with 85-foot diameter antennas spaced approximately 120° apart in longitude around the world. We have a 210-foot antenna at Goldstone, California, and are installing additional ones in Spain and Australia, for operation in 1973.

The major planetary flight program supported last year by this network was the highly successful Mariner '69 mission — our first dual-flight scientific exploration of another planet.

A new high data rate telemetry system — 16,200 bits per second, almost 2,000 times greater than that of Mariner 4 and 5 — aboard the Mariner spacecraft and the use of the 210-foot-diameter antenna at Goldstone allowed for the acquisition of a large number of approach, or far-encounter pictures. The Mariner 6 spacecraft took 50 such pictures, providing full planet views during two rotations of Mars. Mariner 7 sent back 93 far-encounter pictures, showing the changing view of Mars during three rotations of the planet. As the twin spacecraft neared the planet, 57 high and medium-resolution pictures of selected Martian surface areas were obtained and later transmitted to the Goldstone station. All 200 television pictures acquired from the two Mariners were displayed on TV monitors in the con-



"The degree to which various countries participate in tracking activities varies widely, depending on the availability of skilled labor in each host country."

trol center at the Jet Propulsion Laboratory, as they were received from the spacecraft. This immediate display was made possible by the high-rate telemetry system, the 210-foot-diameter antenna, and a microwave link from Goldstone to JPL.

Four on-going Pioneer missions, and Mariner 6 and 7 spacecraft are receiving support in the extended mission phase during FY 1971. Substantial engineering effort is being undertaken to ready the Deep Space Network for support of the Mariner '71 mission and to provide multi-mission capability for such approved, future programs as Pioneer F and G, Mariner/Mercury '73 and the German-NASA cooperative HELIOS project in 1974 and 1975. When the new 210-foot antenna sites

in Australia and Spain become operational in 1973, together with the one at Goldstone they shall provide a three-station network capable of supporting the planetary missions to Jupiter which is over 400 million miles from Earth. It is interesting to note that for such distances the round-trip travel time for radio signals — which travel at the speed of light — would be 80 minutes.

International Cooperation

During the past year, the operations of the two Deep Space Network stations at Madrid, Spain, were assumed by the Spanish. Prior to that time, the stations' operating staffs were a combination of U.S. contractor personnel

and Spanish personnel from the Instituto Nacional de Tecnica Aeroespacial (INTA). As at other overseas locations, and in accordance with the inter-governmental agreements, we encourage the host countries to participate in the NASA program by furnishing operating personnel at the tracking stations. The degree to which the various countries participate varies widely, depending on the availability of skilled labor within the host country. The planned changeover in Spain has benefitted both nations, and as evidenced by the stations' performance in support of recent missions, has been very successful.

In June 1969, the Government of Spain and the United States extended the agreement under which NASA's tracking facilities near Madrid were established and are operated. The original agreement, signed in January 1964, for a term of ten years, was extended for another ten years, to 1984.

Arrangements were made also, in June 1970, for mutual satellite tracking support by the French Centre National d'Etudes Spatiales (CNES) and NASA, whereby each agency will give positive consideration to requests from the other for network support in tracking, data acquisition and command activities of space vehicles when the workload permits. Tracking support will be provided without charge except where a request is made for reimbursement for additional costs directly attributable to the support furnished.

This arrangement will be applicable to support by the French tracking stations in the Canary Islands, Upper Volta, Congo, South Africa, French Guiana and France. NASA stations involved will be primarily those of the Space Tracking and Data Acquisition Network (STADAN) in Australia, Madagascar, South Africa, Ecuador, Chile, England and the United States.



"Intergovernmental agreements provide our first-level working interfaces through the State Department; then in some cases we have second-level interagency agreements between countries; and finally, as in most instances, we have a third-tier working interface — a contractual document."

Cooperation of this nature was made possible through the design of French equipment compatible with that of the United States tracking stations.

We have had a gratifying experience working with the scientists, engineers and technicians who man the tracking stations overseas. Intergovernmental agreements provide our first-level working interfaces through the State Department; then in some cases we have second-level interagency agreements between countries; and finally, in most instances, we have a third-tier working interface — a contractual document.

Additional Support Services

We also provide instrumentation support for aeronautical flight research

programs conducted at the Langley Research Center, Hampton, Virginia, and at the Aerodynamics Test Range of the Flight Research Center, Edwards, California. Our role at Langley consists of telemetry support to their collision avoidance and noise abatement projects; while at the Flight Research Center, which consists of stations at Edwards, California, and Ely, Nevada, we provide communications, telemetry, tracking, and computing support to high-performance aircraft and lifting-body projects.

In this category of short-duration support come also our tracking and data acquisition services for the sounding rockets launched from Wallops Station, Virginia, where ground instrumentation systems such as radar and

optical systems are operated and maintained. By virtue of the equipment and expertise available here, the Wallops Station has been another hub of international cooperative projects.

The Sounding Rocket Program has been providing opportunities for cooperative efforts whereby both the expenses and the acquired scientific data are shared on a no-exchange-of-funds basis. Wallops also maintains a "lending library" of mobile radars available for training foreign personnel toward cooperative projects. Argentina, Brazil, India, Pakistan, and Spain have made use of this equipment.

Global Communications Network

Another function of the NASA Office of Tracking and Data Acquisition is the management of a worldwide communications network for coordinating activities among all stations. We gather data, often in real time and simultaneously from a variety of spacecraft, and transmit these data from the network stations to the project control centers. The NASA Communications System (NASCOM) provides this capability by linking together the foreign and domestic tracking stations, launch areas, test sites, and mission control centers. For this purpose various combinations of leased underseas cable circuits and microwave systems are utilized, as well as satellite service from the Communications Satellite Corporation (COMSAT).

Data Processing Function

In addition to facilities which gather and transmit spacecraft data, we also maintain and operate large-scale, centralized data processing facilities at the Goddard Space Flight Center. The data obtained from flight projects must be processed and presented in a

useable form to interested scientific investigators. This requires the filtering of noise from the data, determination of the trajectory and attitude of the vehicle in space, and correlation of the experiment data with other observations. The objective of this process is to reduce the data to a form that can be understood and interpreted by investigators throughout the world.

Looking at Future Needs

This fast-expanding field of data management activities — including the requirements for initial acquisition, processing to suit users' needs, analysis by the users, and the utilization of these data — presents our cluster of challenges for the Seventies. For example, in deep space telecommunications we shall need the following: to provide spacecraft telemetry at higher rates and at greater distances than now possible; to receive planetary lander data directly from the lander spacecraft; to be capable of the simultaneous operation of several spacecraft; and to devise techniques for obtaining greater tracking accuracies for advanced planetary missions.

To increase the efficiency of our network stations toward future requirements we expect to automate our station activities from the standpoint of checkout, setup, and of minimizing turnaround time.

With the advent of extended capability in communications satellites, we expect to utilize more and more wideband communications transmissions from our network stations. This would make it possible to eliminate the complex data processing equipment at remote stations, to simplify the operation of such stations, to reduce costs, and to place the processing function in the control center for more effective management.

We have also been studying requirements for data relay satellites, for

providing continuous wideband communications suitable for missions such as the Space Station and the Earth Resources Satellite. With increased computer capabilities aboard the Space Station, and relay satellites, it should be possible to send mission-data directly to the control center on a more or less continuous basis. By having almost continuous coverage through the data relay satellite system the requirements for many of the ground stations now needed for low orbiting satellites would be eliminated.

In another related area, that of the Space Shuttle, we expect to see the classical kinds of ground support to be minimized through heavy emphasis on on-board guidance and navigation. But we expect to see some requirements for ground support for the mission phase between launch and orbital insertion. At any rate, such mission requirements and many others shall continue to evolve with the progress of the Space Station and Shuttle definition efforts. Also, before the concepts of the Space Station and Shuttle materialize we shall have the opportunity to test new data acquisition approaches with the Skylab. We are considering, for example, methods of compressing telemetry data by filtering out O.K. conditions and acquiring anomalies only. This would, however, require the use of an on-site computer.

Lastly, with view of improving support to deep space missions we are investigating the use of ever higher frequencies (X-band systems), larger antenna apertures versus arrays of smaller structures, Laser communications that may reduce antenna-size requirements for spacecraft, etc.

Viewing the rapid evolution of the tracking and data acquisition technology we reach the obvious conclusion that communications techniques in general are becoming more reliable and less expensive. **A**



"We have had a gratifying experience working with the scientists, engineers and technicians who man NASA's tracking stations overseas."



MANAGERIAL PERSPECTIVES ON 70'S NEEDS PROJECT TREND OF EVOLUTIONARY CHANGES



Interview with Bernard Moritz *
Acting Associate Administrator for Organization and Management

High selectivity in choosing goals and management tools, sharper focus on system objectives and requirements characterize NASA's austere approach to the Seventies

We are undergoing a period of re-ordered priorities. It is obvious that we will have to operate in the early Seventies with considerably lower funding that we did in the mid and late-Sixties. Planning for future systems will be a major effort in the early Seventies, with follow-on large-scale development activity being dependent upon the availability of resources.

During the Seventies NASA will also emphasize effort toward space applications — based on the sound technological foundation established during the Sixties. To benefit from the experience accumulated during the Sixties we shall maintain the basic organization which has been responsible for the successes of the Apollo; but at the same time we should guard against a tendency to meet the challenges of the Seventies with the success formulas of the Sixties. So organizational implications are that changes will undoubtedly take place, but these will be evolutionary in nature.

As far as managerial centralization versus decentralization is concerned, we have always had some of both in NASA, and I don't foresee any drastic changes one way or the other during the Seventies. This should apply also to program management aspects in NASA-contractor relationships; in general, our contractors have been quite sophisticated and have served the Agency well during the last decade, so I don't anticipate any changes in our relationships during this decade.

More Integrated Planning

If there are any changes to be expected in NASA's decision-making process for the future, these changes will be directed mostly to the integration of basic research pertinent to the Space Shuttle. We shall have more



"A national challenge of a different nature in this decade may turn out to be the maintenance of vitality in our science and technology, in the glare of social and ecological problems impinging on us from all sides."

*Presently, Deputy Associate Administrator for Organization and Management.



"Selectivity is the keynote for the Seventies — be it in the choosing of NASA goals, or in the assignment of our national priorities. Actually, the articulation of new goals for an organization, or for a society, is one of its major managerial challenges. This is the kind of decision-making that promotes revitalization."

integration in our planning process for the future, for one implication of reduced resources is the need for greater centralization to assure the application of these scarce resources to the order of priorities. Nevertheless, the decision-making on research projects will permit flexibility so as to retain a normal measure of decentralization.

Management Latitude for Centers

From a functional viewpoint, we have always provided the Centers with room for flexibility. We feel the Centers need management latitude to be able to cultivate the spirit of innovation as a vital resource. We can't always know the right answers to everything here at Headquarters . . . In the case of the Apollo Program we had the Apollo Management Office located here in Washington; perhaps we could have been just as successful if the Apollo Management Office had been at one of the Centers. We all have a natural tendency to repeat the patterns of our experience that have led to success. Program requirements and needs are seldom identical, however, so we must tailor our management approach to the peculiar needs of each program or project. This is basically the way in which NASA management views most managerial tools and procedures applied at the NASA-industry interface.

For example, when we use a particular structure of Phased Project Planning approach to a project, this is not meant to imply that it is the only way to manage all NASA projects. We don't phase all projects the same way: at times we have merged "A" and "B" phases, and at others "B" and "C". These phases often overlap considerably. So we tend to bring these phases together to use resources as effectively as possible, without definite break points. The important thing is to have

a continuous process of program/project evaluation. In essence, therefore, we use Phased Project Planning as a general guideline; we don't apply it automatically. This also characterizes our attitude toward Incentive Contracting in general. Because of the nature of our contracts we have never used incentives to the extent that DOD has and found them useful on large contracts. As our Director of Procurement Mr. George J. Vecchietti has often pointed out, we use incentives selectively on contract features that are really significant, and want to guard against any procedures or techniques becoming ends in themselves.

Incentives of New Goals

Speaking in a broader sense, selectivity is the keynote for the Seventies — be it in the choosing of NASA goals, or in the assignment of our national priorities. Actually, the articulation of new goals for an organization, or for a society, is one of its major managerial challenges. This is the kind of decision-making that promotes revitalization.

I believe one underlying reason for NASA's successes in the Sixties was the astuteness with which an entire hierarchy of attainable goals were selected in the first place; and many of these were founded on the scientific and technological concepts accumulated through the Fifties. I also believe that it was in keeping with the concept of near-term attainable objectives that no spectacular space goals were pronounced by the President, earlier this year, when he announced our Space Program for the Seventies.

Progress Is Incremental

A national challenge of a different nature in this decade may turn out to be the maintenance of vitality in our

science and technology, in the glare of social and ecological problems impinging on us from all sides. The pressures of these problems may tend to erode public interest and support of scientific and technological endeavor in general. But if such problems are considered important enough to deserve national attention, they should also merit translation into a hierarchy of lesser but attainable objectives, in the true scientific tradition.

NASA's Space Applications program is actually paced by projects that constitute discrete, attainable objectives oriented at least to some of our planet's urgent problems; there are certainly many other challenges, outside NASA's domain, worthy of engaging the energy and idealism of our articulate youth sensitive to the social issues of our times. But the phenomenon of progress — be it individual, social, scientific, or of any other kind — is an incremental process; which makes the establishment of incremental, attainable goals the rational approach to difficult objectives. **A**

"ECONOMY THROUGH CONSCIENTIOUS HOMEWORK"

Interview with William E. Lilly
Assistant Administrator for Administration



"The scarcity of funds in the 70s increases the importance of early investment in program definition, design, and necessary technological efforts that will pay cost saving dividends in the long run."

We are continually challenged to develop improvements in the management of NASA's programs which will make the most of our resources in the current period of rising cost and shrinking budgets.

Since we seldom procure systems in large quantities, the economies obtained by mass production are not typical. Secondly, even though the work force has been decreasing, the cost of its maintenance and that of our facilities has been creeping up with inflation. Our studies indicate that costs in the aerospace sector have increased by approximately 6.5% per year since 1965. We have accomplished significant adjustments to our programs, which are funded in FY 1971 at a level several billion lower than our peak year of 1966. To be

perfectly frank, we have no magic tricks nor esoteric formulas to reveal; and I don't think we are unique in facing this dilemma today, be it in government or in industry. One thing we strive to do, however, is to be more conscientious in preparing our "homework" before committing sizeable resources to new space initiatives.

Former Administrator's Advice

Dr. Paine had a plain piece of advice for anyone tempted to prognosticate program capabilities and costs based more on desire than definition. His counsel was: "let's say less until we know more." The normal decision-making cycle from the initiation of early studies to program commitment takes some 18 to 24 months. During this period, intensive efforts are applied on program definition and point designs, in order to gain an early understanding of technology readiness and the major technical characteristics of the program; in addition, the first "hard" estimates of schedules and cost are made. When industry learns that a certain sum has been allocated to a new program or project, the first thing it wants to know is whether this allocation can be construed as a definite commitment or not. However, this seemingly simple question is always asked prematurely and it is almost impossible to answer until these initial study results are obtained. The scarcity of funds in the 1970's increases the importance of early investment in program definition, design, and the necessary technological efforts that will pay cost saving dividends in the long run.

Program Perspective is Vital

The perspective viewpoint in program management is in effect another requisite toward cost control. In

periods of austerity there will always be a tendency to get enticed by the thought of near-term savings by program stretchouts or other stopgap measures. We were able to keep good cost control in the crucial development phases of the Gemini and Apollo programs by maintaining a proper pace. I think these two programs demonstrated that adequate program definition is needed also to set a cost-effective pace for a program. Then the attainment of predetermined milestones on a firm time-schedule becomes an effective indicator of progress versus dollars. Otherwise, year-by-year decisions to re-adjust the pace of a program can play havoc with the total cost of attaining that objective. Actually, what costs money is people on the payroll, and obviously the longer they remain on a project, the more it will cost.

A further notion that is often nurtured in conjunction with thoughts on economy is the concept of consolidation. There seems to exist a popular belief that when several operations are consolidated, they can be supported at less cost than before. This notion presupposes the existence of duplication of effort in the first place, and to a certain extent matches in validity a certain theory articulated on occasion in support of marriage, which maintains that "two people can live as cheaply as one . . ." The primary area of NASA activity to be studied for possible consolidation in the future will be that of certain support functions at the Kennedy Space Center, with the Air Force.

Balance and Economy

In viewing various cost-savings aspects in a fragmented way we should not lose sight of the fact that NASA's total budget for FY 1971 is characterized not only by economy, but also by a balanced overall program content.



"Year-by-year decisions to readjust the pace of a program can play havoc with the total cost of attaining that program's objective."

This is the lowest budget we have had since FY 1962, and has meant substantial cutbacks and deferrals in a number of programs. As a result, the total nationwide employment on NASA work — which was once 410,000 people — will be reaching a new low of about 143,000 people by next summer.

Here are the principal actions we had to take, based on the decisions in the FY 1971 budget:

- Reduced our operational base, which included the closure of the Electronics Research Center and the cancellation of our Sustaining University program.
- Suspended the production of Saturn V launch vehicles beyond the basic buy of 15 vehicles for the Apollo program.
- Stretched out the Apollo lunar



"We were able to keep good cost control in the crucial development phases of the Gemini and Apollo programs by maintaining a proper pace. I think these two programs demonstrated that adequate program definition is needed also to set a cost-effective pace for a program. Then the attainment of predetermined milestones on a firm time-schedule becomes an effective indicator of progress versus dollars."

- missions to essentially two per year – with a complete gap during the period of Apollo Applications program (now identified as Skylab) operations, during the last part of 1972 and all of 1973.
- Deferred the Skylab program by about four months.
- Postponed the Viking mission to Mars from the 1973 opportunity to 1975 opportunity.
- Deferred the Applications Technology Satellite flights F and G from 1972 to 1973.
- And lastly, reduced the number of remaining lunar missions from six to four.

Some Positive Aspects

As to the positive aspects of FY 1971, these include increased work in aeronautics and cooperative international ventures, as well as the start of Space Station/Space Shuttle design studies and technology effort. Our Space Shuttle work throughout this year will consist of design verification to make certain that we have the technology needed to support the program. This will give us a base for the start of detailed design activity (Phase C) in calendar year 1972.

The main consideration behind the concept of the reusable Space Shuttle is of course, the reduction of the cost of space operations. Therefore, we'll conduct extensive cost-benefit analyses similar to those used to help make decisions on commercial aircraft developments. The ease of maintainability and the multi-use capability are features which make the Shuttle an economical space transport system that could revolutionize the way man utilizes space. The Space Station is another significant new development with similar features of commonality and reusability, which in conjunction with the Shuttle form the key elements in future space operations. 

"REVITALIZING NASA'S MANPOWER RESOURCES"

Interview with Grove Webster
Personnel Division Director, Office of Administration

Viewing NASA's challenges for the Seventies from the standpoint of manpower, the maintenance of continued revitalization looms as the principal source of concern.

Oddly enough, this is not a problem created by the lack of any talent or competence within NASA or outside, but the result of approaching middle-age maturity as an organization, and the constraint of a Civil Service employment ceiling. Our rate of attrition over the years has remained at a low of 6% for professional employees; as a result the age average in NASA has been increasing about eight-tenths of a year each year. And our total number of personnel for the Agency has been reduced to 31,223 as of June 30, 1970. While this situation may not constitute a serious near-term problem, it does raise a question in the long run of how NASA may manage to infuse new blood into its organization, to maintain its vigor of the Sixties.

In context of prevailing manpower constraints, for programs as well as for the Agency as a whole, no overall solution looks likely for the immediate future. We are, however, considering several possibilities for partial solutions, while we continue to revitalize our manpower resources through educational opportunities under the Government Employees Training Act (Public Law 85-507).

One of the recent government programs that will assist toward the infusion of new blood into the executive arteries of NASA is the Executive Interchange Program, launched on September 30, 1969, by the President's Commission on Personnel Interchange. The purpose of this Program is to provide talented young executives at mid-career levels in industry and government with first-hand operating experience in the practices, problems, objectives, and philosophies of the other sector. It is hoped that this



"Since we are operationally specialized and decentralized as an agency, our educational programs are likewise decentralized, and tailored to the needs of our Centers."

Program will help to promote individual understanding and a more effective working relationship between government and industry, and encourage the interchange of management practices.

Participants to this program will serve in bona fide operating positions from a year to eighteen months, on leave-of-absence from their parent organizations, but will remain on the payrolls of those organizations. An initial number of business and government organizations were invited earlier this year to nominate young men and women for participation in the first interchange which began this past summer.

Decentralized Educational Programs

Since we are operationally specialized and decentralized as an agency, our educational programs are likewise decentralized, and tailored to the



"During NASA's peak years of growth in manpower, 1961 to 1964, our training programs were primarily oriented to science and technology; with the leveling-off of growth in recent years we have turned more toward educational programs to enhance the supervisory and managerial skills of our personnel."

needs of our Centers. When we develop a program here at Headquarters, it is mostly to serve as a prototype for the Centers to adapt according to their particular needs.

During NASA's peak years of growth in manpower, 1961 to 1964, our training programs were primarily oriented to science and technology; with the leveling-off of growth in recent years we have turned more toward educational programs to enhance the supervisory and managerial skills of our personnel. An overview of the scope and diversity of NASA's employee development program may be gained from the following outline of educational opportunities and statistics of participation from FY 1970.

Graduate and Undergraduate Studies—NASA encourages job-related academic study at the undergraduate level. However, the Agency considers holders of undergraduate degrees to be only partially trained to meet the requirements for its mission. Therefore, emphasis is placed on the development of individual competence through continuing education at the graduate level.

Participation in FY 1970	
Medical, Scientific, Engineering, Legal and related fields	4140
Technical	329
Administration, Management and Supervision	1109
Other	103
Total	5681

Cooperative Education—This Work-Study Program combines resident academic study in a school, with alternating periods of work, at a NASA Center, which is closely monitored by the school as part of the educational process.

Participation in FY 1970829
(with 136 graduations)

Specialized Training—NASA provides seminars and non-credit short courses, conducted by universities, research institutions, private industry, and other government agencies to assist employees in maintaining competence in a wide range of specialties.

Participation in FY 1970	
Medical, Scientific, Engineering, Legal and related fields	6750
Technical	4165
Administration, Management and Supervision	3495
Other	3852
Total	18,262

Apprentice Training—Through organized on-the-job and related classroom training, NASA's Apprentice Training Program prepares qualified personnel to become journeymen in skilled trades which have particular application to the Agency's needs or those which are in short supply.

Participation in FY 1970237
(with 82 graduations)

Many of these educational programs were established on the basis of studies made in the early Sixties, to determine the professional requirements for scientists and engineers; by the end of this year we shall have completed a study to determine also the skill requirements needed to support research work, and shall develop an overall skills inventory to keep management fully informed on the Agency's human resources.

Lastly, we also provide counselling toward retirement—which in effect might be considered as another form of preparation toward the future. For even after an individual reaches the various optional or mandatory conditions for retirement, the skills and competence he has acquired through a lifetime remain as valuable components of our national resources. **A**



"NASA emphasizes the development of individual competence through continuing education at the graduate level."

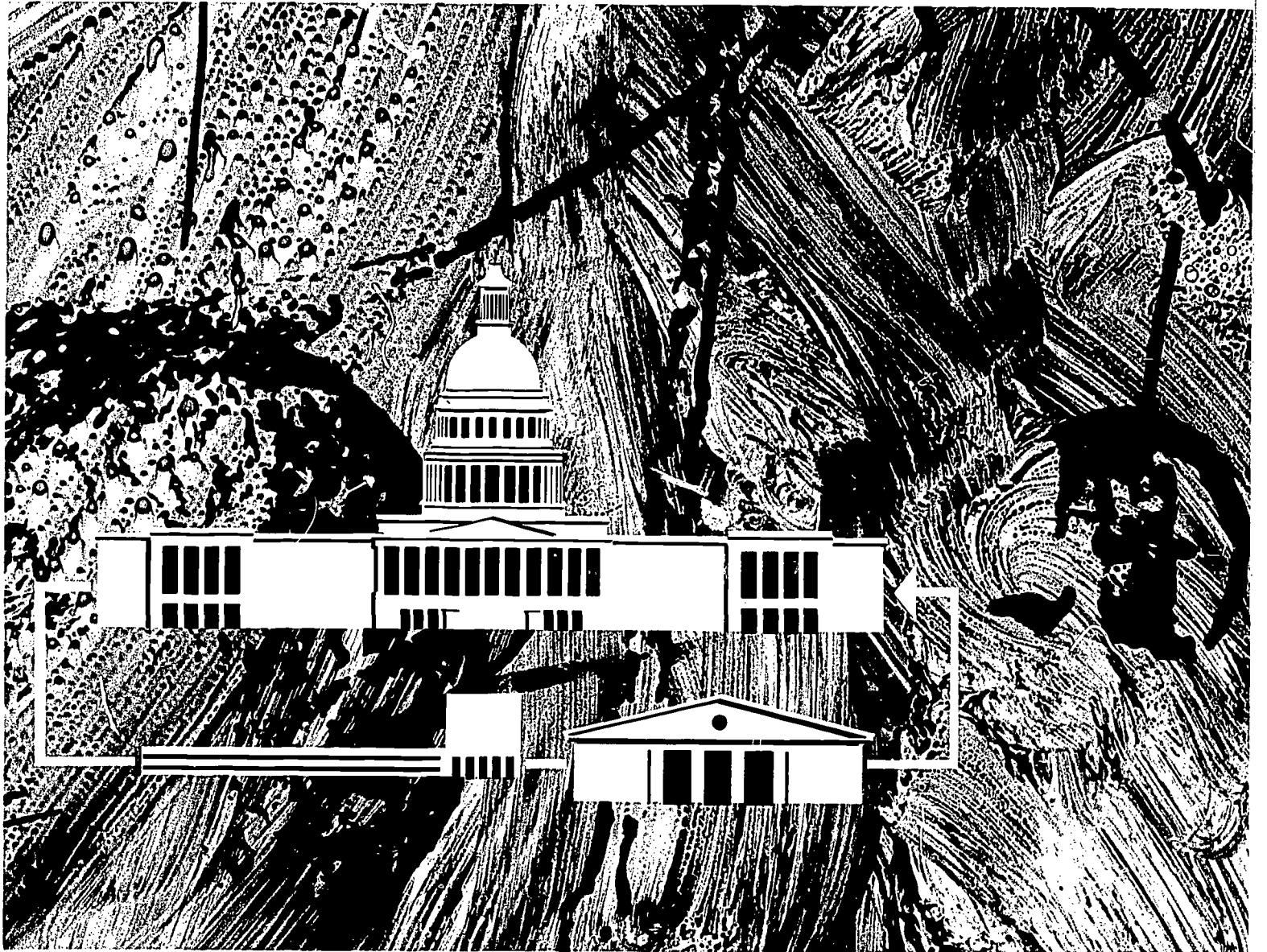

NASA'S MULTIPLE INTERAGENCY INTERFACES BLEND KNOW-HOW TOWARD COMPLEX PROGRAMS



Interview with General Jacob E. Smart, USAF (Ret.)
Assistant Administrator for DOD and Interagency Affairs

Extensive experience in integrating efforts and resources needed for managing complex endeavors, provides useful insights for coping with coming challenges

During its relatively brief span of existence, the National Aeronautics and Space Administration has carried out programs of extreme complexity. It has achieved goals never before attained by man: it has succeeded in sending four American astronauts to the moon, in placing scientific equipment there, and in bringing to Earth lunar samples for study; it has succeeded also in probing the space environment beyond the orbit of Mars by automated spacecraft.

We now have instruments aboard satellites continually observing the Earth, its oceans and atmosphere, and reporting conditions to scientists in laboratories, and to weather stations throughout the world. We have also learned to place space vehicles at the service of man in other very practical ways — to improve communication and navigation, and to survey this planet's finite resources.

Through these achievements we have gained a new perspective of our benign planet: almost insignificant in the vastness of the universe that surrounds it, yet infinitely important to those who inhabit it. We now sense, far better than we understand, our need to learn more about the universe; our solar system; Sun-Earth relationships; the interaction between land masses, the oceans and the atmosphere; and of course the role of man and his wastes in the precariously balanced environment of this planet.

Confidence from New Knowledge

It is in the nature of the expansive mind of man that each new discovery, which pushes back the frontiers of his ignorance, reveals further aspects of reality to engage his mind. And fueled by the confidence gained from each achievement, and new knowledge, man dares to tackle tasks of greater complexity.

We have become greatly aware of

"We now sense, far better than we understand, our need to learn more about the universe; our solar system; Sun-Earth relationships; the interaction between land masses, the oceans and the atmosphere; and of course the role of man and his wastes in the precariously balanced environment of this planet."





"We have become greatly aware of the need to come to grips with the conditions that deny the quality of life to which we aspire."

the need to come to grips with the conditions that deny the quality of life to which we aspire. It is highly significant that this awareness has become particularly pronounced in the era of space exploration. We are only beginning to appreciate the complexities in the way of achieving such a goal, and beginning to size up the scale of national commitment needed both in human and material resources.

Methods and Experience Exist

In the conduct of the nation's non-military space endeavors, NASA has acquired the methodology and managerial experience characteristic of that required for other national endeavors. Certain facets of this methodology and experience can be utilized profitably toward the study of our major social and economic problems. By this I do not mean to imply that the esoteric tools developed in the aerospace field can always be readily fitted to the complexities of other fields. Regardless of how complex they might be, programs addressed primarily to tech-

nological challenges are essentially simpler than programs involving social and economic issues. Also, a major difficulty in the instance of social, economic, and particularly ecological problems is that they are cumulative in nature. They are not problems which have suddenly materialized today; they are the results of conditions that have evolved through the painfully slow and often faltering steps of man to this point in time. And since man's habits and institutions are slow to change, the solutions to the problems he has created are likely to be equally slow in gaining acceptance. Nevertheless, since the underlying characteristic of all endeavors of national dimensions is immense complexity, the managerial experience from comparable previous programs offers aspects worth considering.

Managerial Competence Evolves

The managerial competence displayed by NASA in the conduct of the space program, and by the Department of Defense in the Manhattan Project, the ICBM programs, and in other major developmental endeavors, is a product of evolutionary processes. The Apollo program benefited in many ways from the programs that preceded it, as well as from the talents of the men who made the earlier programs successful.

Commitment to the Apollo program brought the realization that the resources of the nation had to be marshaled. No single agency — not even the office of the President — is endowed with the responsibilities, authorities, or resources required to pursue to completion a relatively simple program as the Apollo. The authorities and the responsibilities required for Apollo include those that are vested in the President, the Congress, other federal agencies, the various states,

universities, multiple technical and social institutions, and of course those that remain the province of the American people. All of these contribute toward the achievement of success. Think how much more widely spread are the authorities required, for example, for the conduct of a national program to control pollution of our water or atmosphere, or for the disposal of human and industrial waste.

A second realization, from the experience of launching programs of national dimensions, has been that instead of creating new institutions, the capabilities of existing ones should be put to use. The Apollo program utilized the competence of industry, business, university, and government. Some 90% of all dollars appropriated to NASA were spent through other agencies. A corollary to this tenet is that participating institutions should be strengthened rather than drained of strength by virtue of their association with the endeavor. NASA made a particular effort to utilize universities for research, new and broadened concepts, and strengths of lasting value that would enable the universities to perform their primary and continuing role more effectively.

Third, new knowledge and the development of new technological competence are indispensable ingredients for achieving far-advanced goals. Highly competent scientists and engineers — specialists who need long lead-times for education and training — must be readily available and willing to focus their talents upon identified problem areas; and managers must maintain the flexibility to capitalize upon unexpected breakthroughs of far-reaching significance. New knowledge and new competence that are derived from many fields constitute the significant by-products of major national endeavors such as the space program.

Fourth, centralized leadership and control must be exercised by men who



"NASA has made a particular effort to utilize universities in a manner that would develop new knowledge and competence, new facilities for research, new and broadened concepts, and strengths of lasting value that would enable the universities to perform their primary and continuing role more effectively."



"In pursuit of our national aspirations to improve the quality of life, we shall undoubtedly encounter a greater need to meld efforts from multiple institutions."

can organize and direct the strengths of individuals and institutions. Leadership is an elusive but essential quality. The more complex the endeavor, the greater is the requirement for the kind of personal leadership which can persuade and inspire groups of divergent orientation to work toward a common goal. A major national program is successful only to the extent that it gains and maintains the support of multiple independent agencies that control the authorities, responsibilities, and resources required for the pursuit of that program. This necessitates a continuing commitment by the supporting agencies, and this in turn requires mechanisms for keeping the interfaces viable and mutually beneficial. The adjacent NASA Headquarters organization chart reflects the interfaces that the agency needs to operate effectively. Note that the NASA Headquarters staff includes the following:

- Office of DOD and Interagency Affairs
- Office of Industry Affairs
- Office of International Affairs
- Office of Legislative Affairs
- Office of Management Development
- Office of Public Affairs
- Office of University Affairs

Each of these offices is concerned with specific facets of activity which enable NASA to conduct its programs in touch with and in context of the realities of its environment.

Products of NASA's Endeavors

A number of other agencies are also interested in the products of NASA's endeavors. Business, industry, universities, and government are interested in new technology. Universities are interested in new technology, new materials, new concepts. Various governmental departments frequently require help in coping with specific problems.

NATIONAL AERONAUTICS AND SPACE ADMINISTRATION

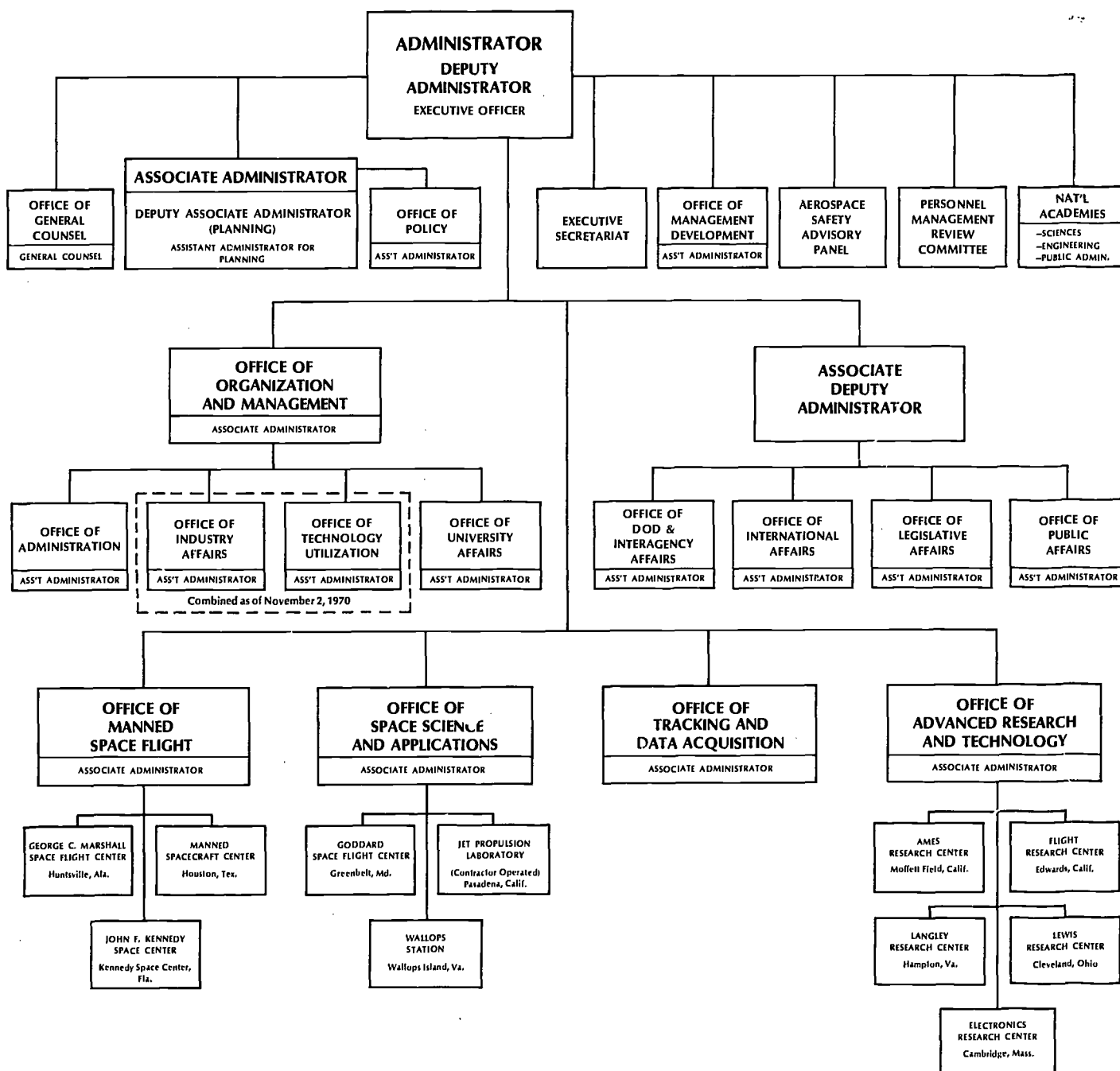



"A major national program is successful only to the extent that it gains and maintains the support of multiple independent agencies that control the authorities, responsibilities, and resources required for the pursuit of that program."

The Department of Transportation, for example, seeks help in coping with the problems of jet aircraft noise and noise control in general, in air traffic control, and in improved altimetry. The Housing and Urban Development Department seeks knowledge of new materials and newly discovered properties of old materials — of fire causes and fireproof and fire-resistant materials, waste disposal, safety, etc.

Another aspect of NASA Headquarters organization, as reflected in the adjacent chart, is the fact that NASA directs effort also to providing products and support to other agencies and institutions. Such activities are conducted through the following staff offices:

- Office of International Affairs
- Office of Technology Utilization
- Office of University Affairs

High-Level Advisory Bodies

The interdependence of the various agencies of government and the working relationships between the government, industry, universities, and other social institutions, have necessitated the establishment of high-level advisory bodies. Mechanisms to achieve coordination and cooperation have been established by the Congress and by Executive Order. Among the major ones that influence NASA's objectives and the means and methods by which we pursue them are the following:

National Aeronautics and Space Council has the responsibility to advise and assist the President on policies, plans, and programs in aeronautics and space. Membership is comprised of the Vice President of the United States as Chairman, the Secretary of State, the Secretary of Defense, the Administrator of the National Aeronautics and Space Administration, and the Chairman of the Atomic Energy Commission.

Council on Environmental Quality evaluates existing and proposed policies and activities of the Federal Government directed to the control of pollution and the enhancement of the environment, and it advises and assists the President as a staff in this category.

Federal Council for Science and Technology (FCST) was established by President Eisenhower in 1959. The agencies it represents are:

Atomic Energy Commission
Department of Agriculture
Department of Commerce
Department of Defense
Department of Health, Education, and Welfare
Department of Housing and Urban Development
Department of the Interior
Department of State
Department of Transportation
National Aeronautics and Space Administration
National Science Foundation
Office of Science and Technology

The following agencies are represented at Council meetings by official observers:

Arms Control and Disarmament Agency
Bureau of the Budget
Council of Economic Advisers
Department of Justice
Office of Economic Opportunity
Smithsonian Institution
Veterans Administration

Purpose of the FCST is to promote cooperation in planning Federal R&D programs by the agencies, and to assist in advancing and strengthening the scientific efforts of the U.S. The FCST is advisory to the President and to the heads of the agencies represented.

President's Science Advisory Committee (PSAC) advises the President on matters studied at his request and on matters studied on its own initiative. It

plays a role in blending governmental and non-governmental views to achieve a total approach to problems involving science and technology.

National Academy of Sciences (NAS) is a private society of distinguished scholars in science and engineering, dedicated to furthering the general welfare. It serves the Government by making studies under grants and contracts.

National Academy of Engineering (NAE) is a parallel organization to the NAS. It is composed of distinguished engineers and is autonomous in its administration. It shares with the NAS its responsibility for advising the Federal Government.

National Research Council (NRC) is the operational arm of the NAS and the NAE. Members of the NRC are selected as required from universities, industry, and the Federal Government.

Converting Vision to Reality

This brief discussion has touched on a number of organizational roles and working interfaces; hopefully, it has provided an overview of the inter-agency mechanisms by which the authorities and resources vested in various national institutions can be coordinated for coping with major programs of national significance.

In pursuit of our national aspirations to improve the quality of life, we shall undoubtedly encounter greater need to meld efforts from multiple institutions; we shall also face an acute need for men endowed with vision and competence to match the complexities in the way of fulfilling these aspirations.

On numerous occasions in the past we have marshaled the strengths of the nation to convert vision to reality. What we have learned in the process should provide valuable clues for dealing with the challenges of this new decade.



"On numerous occasions in the past we have marshaled the strengths of the nation to convert vision to reality. What we have learned in the process should provide valuable clues for dealing with the challenges of this new decade."



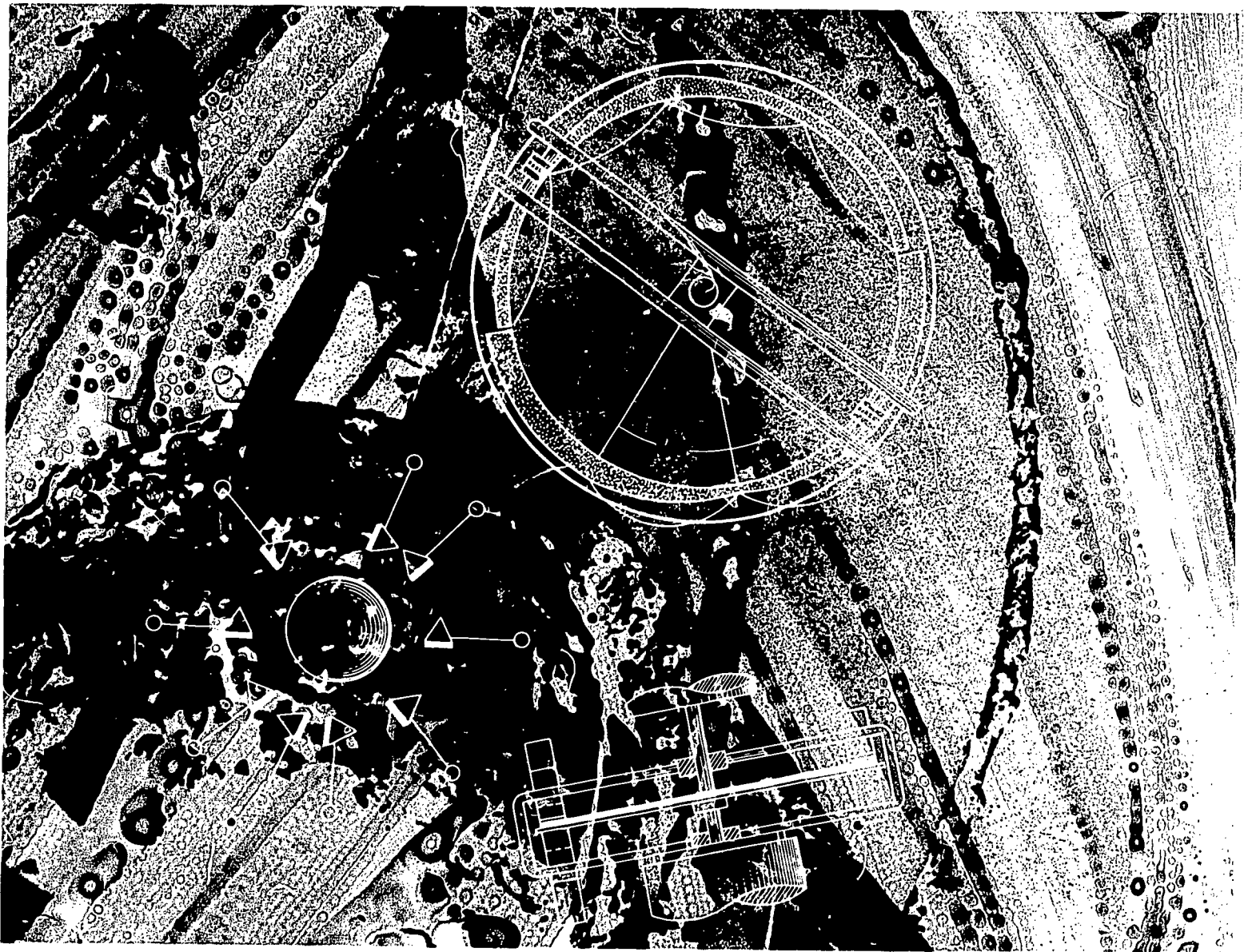

NASA'S OFFICE OF TECHNOLOGY UTILIZATION* FEEDS USEFUL CONCEPTS TO PUBLIC SECTOR



Interview with Melvin S. Day
Acting Assistant Administrator for Technology Utilization, NASA Headquarters

Wide variety of specialized publications and information centers make findings from space-oriented technology accessible to commercially-oriented entrepreneurs

A peculiar property of most labels is that they stick to the things they identify as if by epoxy glue. And that's the way it has been with the term "Space Technology" — somewhat of a misnomer. Space Technology is in reality U.S. industrial technology used for space purposes, but also very useful here on Earth.

The distilling and transmittal of new knowledge gained from NASA's aerospace oriented work to the American public, the industrial medical and academic communities is the function of NASA's Office of Technology Utilization. Normally, it takes about seven to ten years to put a newly-invented process or tool into widespread use; we are involved in accelerating this process. New technological concepts — developed within NASA or under NASA contracts — are harvested by the Technology Utilization Offices of all the NASA Centers and installations, and concepts with commercial potential are announced through several categories of publications. These publications, which are sold singly or by subscription, are as follows:

Tech Briefs: Terse one or two-page bulletins describing new solutions to old problems, or novel solutions to unusual problems. Readers may obtain more detail information — such as test data, drawings and specifications — by writing to an indicated Technical Utilization Officer. Tech Briefs cover innovations of the following categories: Electrical (electronic), Physical Sciences (energy sources), Materials (chemistry), Life Sciences, Mechanical, and Computer Programs. Tech Briefs may be obtained from the Clearing-

house for Federal Scientific and Technical Information; Attention Code 410.19, Springfield, Va. 22151.

Another category of publications from the Technology Utilization Program is identified as Special Publications. These explain new concepts, designs, techniques, materials, and equipment. Some constitute surveys of broad fields; others are detailed accounts of especially significant developments. There are several kinds of Special Publications:

Technology Utilization Compilations: Collections of closely-related incremental advances in the state of a given art. Examples: Machine Shop Measurement; Tools, Fixtures, and Test Equipment for Flat Conductor Cables, etc.

Technology Utilization Reports: Descriptions of innovations of special significance or complexity. These are more detailed announcements than

Tech Briefs, and bear such titles as: Selected Casting Techniques; Joining Ceramics and Graphite to Other Materials; Adhesive Bonding of Stainless Steels, etc.

Technology Surveys: Consolidations of the results of NASA-sponsored R&D efforts that have advanced whole areas of technology. Written by noted authorities in specific fields, these "guidebooks" may cover: Solid Lubricants; Magnetic Tape Recording; Thermal Insulation Systems, etc.

Conference Proceedings: Publications covering NASA-sponsored meetings for particular industries and groups. At such conferences scientists and engineers who have made major contributions to technology review their work. A pamphlet describing NASA's Special Publications can be obtained from any of NASA's Technology Utilization Offices, and these

"Technology transfer to the biological and medical fields is not a rapid process because it often requires extensive testing by the medical community before acceptance and general use."



*Subsequent to this interview the Office of Technology Utilization and the Office of Industry Affairs were combined, as of November 2, 1970, into the Office of Industry Affairs and Technology Utilization headed by Daniel J. Harnett. Melvin S. Day is presently Deputy Assistant Administrator for Technology Utilization, and George J. Vecchietti the Deputy Assistant Administrator for Industry Affairs.



"Space Technology is in reality U.S. Industrial technology used for space purposes, but also very useful here on Earth."

publications may be purchased either from the Clearinghouse or from the U.S. Government Printing Office, Washington, D.C. 20402.

Computer Program Abstracts: An indexed, quarterly abstract journal listing documented computer programs developed by or for NASA, DOD, AEC. These abstracts may be purchased through NASA-sponsored Regional Dissemination Centers and the Computer Software Management and Information Center (COSMIC). These Centers are discussed later in this article.

International Aerospace Abstracts: An abstracting and indexing service covering the world's published literature on aeronautics and space science and technology. Publications covered in these semimonthly abstracts include: periodicals (including government-sponsored journals) and books; meeting papers and conference pro-

ceedings issued by professional societies and academic organizations; translations of journals and journal articles.

Scientific and Technical Aerospace Reports (STAR): A comprehensive abstracting and indexing journal, STAR covers current worldwide report literature on the science and technology of space and aeronautics. Publications abstracted in STAR include scientific and technical reports issued by NASA and its contractors, other U.S. Government agencies, and corporations, universities, and research organizations throughout the world. Information on STAR and on the availability of the International Aerospace Abstracts to organizations having contractual arrangements with NASA may be obtained from: National Aeronautics and Space Administration, Scientific and Technical Information Division; Attention: Code USI; Washington, D.C. 20546.

Regional Dissemination Centers

As the history of industrial evolution attests, new knowledge is acquired in bits and pieces more often than in ready-to-use packages. To solve a problem in one context, information acquired for a number of other purposes often must be pulled together, applied to the specific situation, and possibly expanded by further study of individual requirements. To provide so-called packages of new technology — oriented to individual needs — NASA has established six Regional Dissemination Centers. No two of these Centers are alike; each one, however, is based at a university or not-for-profit research institute, and staffed with professional personnel skilled in the use of computer search-and-retrieval techniques to assemble information. Addresses of these Centers are as follows:

AEROSPACE RESEARCH APPLI-

CATIONS CENTER — Indiana University Foundation, Bloomington, Ind. 47405. Phone: 812 337-7970.

KNOWLEDGE AVAILABILITY SYSTEMS CENTER — University of Pittsburgh, Pittsburgh, Pa. 15213. Phone: 412 621-3500, ext. 6352.

TECHNOLOGY APPLICATION CENTER — University of New Mexico, Box 185, Albuquerque, N. Mex. 87106. Phone: 505 277-3118.

NEW ENGLAND RESEARCH APPLICATION CENTER — University of Connecticut, Storrs, Conn. 06268. Phone: 203 429-6616.

NORTH CAROLINA SCIENCE AND TECHNOLOGY RESEARCH CENTER — Post Office Box 12235, Research Triangle Park, N.C. 27709. Phone 919 834-7357 or 549-8291.

WESTERN RESEARCH APPLICATIONS CENTER — University of Southern California, Los Angeles, Calif. 90007. Phone 213 746-6133.

Since each of these Regional Dissemination Centers is set up to be responsive to a specific geographic and economic environment their services and fees vary somewhat. These Centers provide the following types of services:

Current Awareness Searches: Computer tapes bearing some 6000 new citations of scientific and technical reports are searched each month for items of likely value to each client. This is done by machine-matching a "customized interest profile" of the client's objectives, problems, needs, and desires against indexed descriptions of aerospace researchers' findings. Specialists then screen the citations thus obtained, for relevance and quickly forward the results to the client. He then may request and receive full copies of whichever documents among those cited, that he decides may be useful to him.

Retrospective Searches: More thorough searches are made in re-



"Through a cooperative agreement between NASA and the Small Business Administration (SBA), small businesses are referred by the SBA to Regional Dissemination Centers, and given a limited number of searches for information at a special rate."

sponse to clients' specific questions. Computer tapes bearing over 500,000 citations of previous as well as the most recent additions to the aerospace library are machine-searched. The output is evaluated by the Center's experts and sent to the company or person who posed the question. Copies of the documents located in this manner are also sent when requested.

Standard Interest Profiles: These may be obtained from Centers by companies or individuals who require information in somewhat broader categories for current awareness purposes.

The Regional Dissemination Centers send the previously described Technical Utilization publications to their clients each week and also supply backup data.

Data bases available at these Regional Centers are being steadily augmented. We have added DOD unclassified data and reports, material from

the Chemical Abstracts Service of the American Chemical Society, and data bases in electronics and plastics from Engineering Index, Inc.

Computer Program Services

We have also made government-generated computer "software" a part of the total mix of services offered by the Centers. The Computer Software and Management Information Center (COSMIC) is located at the University of Georgia. This Center collects, evaluates and distributes tapes, card decks, machine-run instructions and listings from NASA, AEC and DOD computer programs. To date over 18,000 orders have been filled by COSMIC. All the Regional Dissemination Centers and COSMIC sell software at prices based on the costs of reproduction and distribution. Further information about this service is available from any

of the Regional Dissemination Centers, or from: Director, COSMIC, University of Georgia Computer Center, Athens, Ga. 30601. The NASA Office of Technology Utilization also issues the quarterly journal entitled "Computer Program Abstracts", available from the Government Printing Office on an annual subscription basis.

Technology Transfer to Biomedicine

Another activity of NASA's Technology Utilization Program is directed to the identification and communication of space technology concepts which may provide solutions to medical or biological problems. This work is done by three Biomedical Application Teams of multidisciplinary membership from both the aerospace and biomedical communities. "Medical Problem Abstracts" prepared by these teams are used (1) to search NASA's computerized information bank for relevant discoveries and innovations, and (2) to solicit guidance and suggestions for aerospace scientists and technicians for biomedical specialists. Technology Utilization Officers assist these teams to tap the resources of NASA's field installations. More information about these teams' activities may be obtained from the Director, Biomedical Application Team, at any of the following three research institutes:

MIDWEST RESEARCH INSTITUTE - 425 Volker Boulevard, Kansas City, Mo. 64110.

SOUTHWEST RESEARCH INSTITUTE - 8500 Culebra Road, San Antonio, Texas 78206.

RESEARCH TRIANGLE INSTITUTE - Post Office Box 12194, Durham, N.C. 27709.

With regard to biomedicine, the Technology Utilization Program serves two purposes: (1) it seeks answers from aerospace knowledge for speci-

fied medical questions, and (2) it identifies aerospace technology that appears to have potential medical value, then searches for biomedical objectives that this technology may help to meet. The Office of Technology Utilization has a cooperative pilot effort with the Vocational Rehabilitation Administration (VRA) aimed in particular at the problems of the four million adults of the country who have physical or mental disabilities.

Vocation rehabilitation scientists at four VRA-supported university research centers specify their unsolved problems in restoring the disabled to productive life. NASA then seeks out information resulting from aerospace research that appears to be applicable to the problems of the handicapped. This information is relayed to the VRA for evaluation, application through adaptive engineering, demonstration of the resulting devices and procedures, and encouragement of commercial introduction of the new products and services.

Other Interagency Interactions

The VRA-NASA efforts are part of a wider interaction between NASA and other government agencies to establish informational exchanges and working relationships. Such relationships have been established with beneficial results, also with federal and state agencies concerned with the application of engineering and management technology to mine safety, pollution control, law enforcement, and transportation. These cooperative efforts are being assisted by two relatively new Technology Application Teams, located as follows:

ILLINOIS INSTITUTE OF TECHNOLOGY RESEARCH INSTITUTE, 10 W. 35th Street, Chicago, Ill. 60616.
STANFORD RESEARCH INSTITUTE, Menlo Park, Calif. 94025.

Both teams are composed of individuals from a variety of scientific and engineering disciplines. Their assignment is to transfer aerospace technology to areas of concern in the public sector, through an interdisciplinary approach to problem solving.

The user agencies with which we have worked on the Federal level include the Law Enforcement Assistance Administration (in the Department of Justice); The Bureau of Reclamation, Bureau of Mines, and the Federal Water Pollution Control Administration (in the Department of Interior); the Bureau of Solid Waste Management and the National Air Pollution Control Administration (in the Department of Health, Education and Welfare); the Department of Transportation; and the Department of Housing and Urban Development. Public agen-

"Technology transfer is a slow process, requires interdisciplinary creativity which is always in short supply, and requires resources."



cies on the state and local level with which we have worked to date include the Los Angeles, Seattle, New York, and Chicago Police Departments; the Maryland, Illinois State Crime Commissions and the New York Office of Crime Control Planning; the Bay Area, Los Angeles and Seattle Air Pollution Control Districts, plus other local air-pollution authorities; the Los Angeles and Bay Rapid-Transit Authorities; and the Chicago, Boston, and Los Angeles Fire Departments.

These cooperative problem-solving efforts have begun to pay off. Among recent transfers are a compact, self-powered, easily portable device for monitoring dust particles in coal mines; a sensor for the measurement of low-velocity air flow in coal mines; a scanning instrument for the detection and recovery of indented writing in criminal laboratories; an instrument to determine the sensitivity of automobile drivers to various air pollutants; the application of NASA mass spectrometers for monitoring air pollution; and the development of a portable life-support system for use by firemen.

In context of interagency activities, I would like to cite also our association with the Small Business Administration (SBA). A vital communication function is performed by the SBA in bringing the benefits of government-sponsored R&D to the attention of small manufacturers and companies as potential users. Through a cooperative agreement between NASA and SBA, small businesses are referred by the SBA to the Regional Dissemination Centers, and given a limited number of searches for information at a special client-free rate. Cooperative activities between NASA and the SBA extend to seminars, workshops, publications, and various other experimental data-dissemination efforts. We are particularly pleased to sponsor one program that

has become a landmark experiment in technology transfer to small business. The TECHNOLOGY USE STUDIES CENTER, Southeastern State College, Durant, Oklahoma, has worked for over six years with small businesses in a non-urban region of 19 counties in Southeastern Oklahoma. The economic impact of this operation has been significant.

Contributions to Education

The location of Regional Dissemination Centers within university communities often contributes to viewing each Center also as a major on-campus resource. For the documents represented by the RDC information base outnumber the library holdings of many of our colleges and universities.

We are also testing ways of accelerating the infusion of new scientific and technical knowledge — from aerospace R&D — into graduate and advanced undergraduate engineering curricula. To this end Oklahoma State University, under contract to NASA, selects source material from NASA R&D reports from which texts are written in an educational format for use on a trial basis, as supplementary teaching aids. Over one hundred universities have requested monographs for review and classroom use, and a number of industrial concerns have found them useful for their continuing education programs. We hope that eventually another institution will sponsor further development of this concept, as a means for enhancing the quality of formal engineering education.

Often Asked Questions

We are often asked why the results of aerospace research do not swiftly become translated into commercial benefits to the public. One reason for this, as I said earlier, is that most new advances are incremental in nature,

NEW TECHNOLOGY REPORTING REQUIREMENTS

All Government contracts concerning scientific and technical development contain clauses defining the responsibilities of contractors with regard to the disclosure of inventions developed under contract, and with regard to the status of patent rights of these inventions. Further, under the provisions of the Space Act of 1958, Congress has directed NASA to insure that developments resulting from scientific and technological programs are retrieved and made available to the maximum benefit of the Nation's industrial effort in the shortest possible time. This direction has resulted in the placement of a New Technology Clause in most NASA contracts, which requires contractors to separately identify resulting inventions or innovations and to report them promptly. This clause provides for a penalty, in the form of substantial payment withholdings, for noncompliance. Other Government agencies, such as DOD, AEC, HEW, etc., have similar requirements for reporting inventions and innovations developed under their contracts.

NASA'S INFORMATION SYSTEM

In compliance with the Space Act of 1958, which established NASA and stipulated that it should "provide for the widest practicable and appropriate dissemination of information concerning its activities and the results thereof," NASA created its Office of Technology Utilization. Two of its divisions provide the following informational assets and services:

1. Scientific and Technical Information Division provides a stockpile of readily-tapped knowledge from domestic and foreign aerospace sources—presently more than 500,000 scientific and technical documents, announced in abstract journals, indexed on computer tapes, and distributed in printed copies and on 4-by-6-inch rectangles of microfilm, called microfiche. The stockpile is increased by reports and articles—approximately 75,000 a year at the current rate—from NASA's research centers and field offices, from its contractors and grantees, from other branches of the Government that produce technological information, from aerospace activities in more than 40 foreign countries around the world. Among the more than 6,000 research reports added to this accumulation in an average month are about 500 on biosciences and biotechnology.

2. The Technology Utilization Division selects from the computer-indexed stockpile, and from on-going research and development projects, those discoveries, inventions, ideas, and new techniques that have possible use in the non-aerospace community—including the biomedical field. This division also seeks out useful new ideas resulting from NASA work not otherwise reported in the scientific literature.

and not in the form of major developments. Secondly, these new concepts must be pulled out of one context and applied to a problem in a totally unrelated area. This is a time-consuming process, requires interdisciplinary creativity — which is always in short supply — and requires resources. Therefore, unless a new concept looks immediately promising from a commercial viewpoint, companies don't seem inclined to invest toward its development. Technology transfer within the public sector is relatively easier, where a need exists, because federal, state and local governments can adopt a useful concept — if it relates to public health or safety — without concern over commercial returns.

Technology transfer to the biological and medical fields is not a rapid process because it often requires extensive testing by the medical community before acceptance and general use. For this reason, we work closely with the medical community, pointing out the biomedical applications that look promising, and leave their testing and development for use to the medical community.

The profit motive is, of course, a powerful accelerator of technology transfer, but we are as a nation also facing more and more the pressures of our greater problems that are begging for new solutions. For example, the regenerative waste management systems for spacecraft may point the way for our growing waste disposal problems here on "Spacecraft Earth". At the rate we are generating refuse today, the old concept of "disposal" seems destined for replacement by the concept of "recycling". This may, in turn, call for a revamping of materials, manufacturing, packaging, and perhaps may even lead to the rise of a new breed of technologists in our society — the "Biodegradability Specialists. . . ."



PATENTS AND LICENSING POLICY

Interview with Gayle Parker
Patent Attorney, Office of General Counsel



"Since the time of the passage of the Space Act of 1958, our patent policy has been evolving more toward government-wide uniformity in the allocation of rights to inventions arising from government-funded R&D to the government."

NASA activities centering on patents and licensing are closely related to the process of technology transfer. Patents and licenses serve to stimulate invention and provide incentives for translating new concepts into products and processes of broad commercial usefulness.

A patent is, of course, a government grant to an inventor, for a term of 17 years, of the right to exclude others from making, using, or selling the invention. What NASA produces the most is a mass of new knowledge, which as such is not patentable. But a considerable number of individual

NASA inventions have commercial applications, and are patentable. Congress recognized this in the Space Act of 1958 by stating that:

"Whenever any invention is made in the performance of any work under any contract of the Administration . . . such invention shall be the exclusive property of the United States, and if such invention is patentable a patent therefore shall be issued to the United States upon application made by the Administrator, unless the Administrator waives all or any part of the rights of the United States . . . and the Administrator shall promulgate licensing regulations upon which licenses will be granted for the practice of any invention for which the Administrator holds a patent on behalf of the United States."

In our Technology Utilization efforts we may come across individual concepts of potential usefulness, or an entire family of inventions — like fire-resistant materials, inorganic compounds, etc.; each separate and distinct invention in such a family must be patented separately.

Government policies regarding the disposition of invention rights were revamped considerably during the last twenty years. These changes evolved as a result of the shifting of the government's research and development work from federal arsenals to private industry after WW II. Since the time of the passage of the Space Act of 1958, our patent policy has been evolving more toward government-wide uniformity in the allocation of rights to invention arising from government-funded R&D to the government.

Memorandum On Patent Policy

A significant Executive action in this area was President Kennedy's Memorandum and Statement of Government Patent Policy issued

October 10, 1963, for the Heads of Executive Departments and Agencies. Here are the principal considerations highlighted by this Presidential Memorandum:

- "It is not feasible to have complete uniformity of practice (in the disposition of rights to inventions made under contracts with outside organizations) throughout the Government in view of the differing missions and statutory responsibilities of the several departments and agencies engaged in R&D. Nevertheless, there is need for greater consistency in agency practices in order to further the governmental and public interests in promoting the utilization of Federally-financed inventions and to avoid difficulties caused by different approaches.

- "A single presumption of ownership does not provide a satisfactory basis for Government-wide policy on the allocation of rights to inventions. Another common ground of understanding is that the Government has a responsibility to foster the fullest exploitation of the inventions for the public benefit.

- "This policy seeks to protect the public interest by encouraging the Government to acquire the principal rights to inventions in situations where the nature of the work to be undertaken or the Government's past investment in the field of work favors full public access to resulting inventions.

- "The public interest might also be served by according exclusive commercial rights to the contractor in situations where the contractor has an established nongovernmental commercial position and where there is greater likelihood that the invention would be worked and put into civilian use rather than would be the case if the invention were made more freely available.

- "Wherever the contractor retains more than nonexclusive license, the policy would guard against failure to

practice the invention by requiring that the contractor take effective steps within three years after the patent issues, to bring the invention to the point of practical application, or to make it available for licensing on reasonable terms.

- "The Government would also have the right to insist on the granting of a license to others, to the extent that the invention is required for public use by Government regulations or to fulfill a health need, irrespective of the purpose of the contract."

It should also be noted that the President's statement of Government Patent Policy calls for the preparation of a report, at least annually, by an interagency Federal Council for Science and Technology, in consultation with the Department of Justice. The purpose of this report is to analyze the effectiveness of the policy, and to make recommendations for revisions or modification — as believed necessary in light of the practices of the Government agencies under the policy. Recently, the Federal Council for Science and Technology recommended to President Nixon that the Presidential Policy Statement be modified by adding language that would encourage Government agencies to grant exclusive licenses on Government-owned patents under their administration to promote commercial utilization . . . similar to NASA's patent licensing program.

Contribution to Public Interest

The top-management recognition of and the consequent impetus provided to the Technology Utilization Program are among the original contributions made by our former Administrator James Webb. He had a unique understanding of the contribution of inventions to the public interest, and gave this matter top priority. Exclusive



"NASA may waive all or any part of the rights in an invention to the contractor who made it — if the Administrator determines the waiver is in the public interest."

rights to NASA inventions were granted starting in 1963, and NASA became the first agency with a progressive licensing program — a necessary function for stimulating the transfer of technology; recently, the AEC, HEW and the Department of Agriculture have also expanded their patent licensing programs.

Search for Commercial Potential

Our inventions are derived from NASA's in-house research, or contractor efforts. Of the approximately 5000 inventions identified each year, about 350 come from our in-house work. When a new concept is identified, the Technology Utilization Officer of the NASA field center involved sends copies of the concept description to the resident Patent Counsel, for patent action. The Technology Utilization Office evaluates new concepts primarily for commercial potential; if such a potential is evident, the idea is sent to a not-for-profit research contractor to evaluate further, and to determine the commercial potential. Concepts with commercial potential are documented and published as Tech Briefs (discussed in the preceding article) and distributed to subscribers. Some 3600 invention concepts have been disseminated to date, via Tech Briefs, to our industrial community.

Inventions are studied at our NASA field centers, for technical significance and patentability. For selected patentable inventions, patent applications are filed in the U.S. and a few are chosen for foreign patents. Such inventions become NASA's exclusive property and are made available for licensing.

Waiver Option

However, NASA may waive all or any part of the rights in the invention to the contractor who made it — if the Administrator determines that a

waiver would be in the public interest. Nevertheless, the government always reserves the right to use such inventions for its own purposes. There are some categories of invention, such as those involving public health, in which waivers are usually not granted. A typical case of this nature, which involved public health, was for a medical electrode that could be attached to the human body to sense the heart-beat rate. NASA Tech Briefs indicate whether a patent has been applied for that invention, or not, and thus alert commercial companies which may be interested in applying for license.

To encourage the earliest possible commercial use, all inventions owned by NASA for which patent applications have been filed, or that have been patented on behalf of NASA, are available for royalty-free licensing to American firms; licensees of foreign patent rights are required to pay royalties.

If an invention is not reduced to commercial form within two years after a patent has been issued, then NASA makes the invention available on an exclusive basis in order to stimulate interest in using it commercially. In other words, we grant exclusivity to justify investment toward development.

Accounting Necessary

In the case of non-government commercial licensing agreements, an accounting must be made for royalties. In the government licensing programs, for example, the licensee may be asked what he is doing to develop and promote the invention, how much is being spent to these ends, and how many units have been sold. We need such data for our evaluation of the Technology Utilization Program and for reporting to Congress, also for the Federal Council for Science and Technology.

To date the number of patents issued to NASA is about 1050, and there are some 650 patent applications pending. This is a harvest resulting from the evaluation of approximately 22,000 since 1958. As a reference figure, the total number of patents owned by the government is about 20,000.

The only sector of technology we haven't been much involved in, by our patent and licensing activities, has been that of computer programs. This is because until recently software had not been considered as patentable. Lately, though, court decisions have somewhat modified the ban against the patenting of software. As explained in the previous article, we have developed a considerable library of software packages and we sell these at cost.

Opportunities Lie Dormant

A significant aspect of technology utilization and licensing is that NASA has recognized the possibilities that exist to make dormant opportunities come to life and pay off. The transfer of technology between government agencies continues to be relatively easy, particularly for inventions which bear on public welfare or safety, or are required for use by government regulation. A so-called cross-fertilization of concepts continues to take place also through the normal transfer of individuals from one government agency to another.

Reluctance to Investigate

Technology utilization faces two problems. The first is the so-called NIH (not invented here) factor which reflects partly a natural mistrust of the unfamiliar (and possibly only partially understood) and partly hesitancy to rely as fully on the work of a stranger,



"To encourage earliest possible commercial use, all inventions owned by NASA for which patent applications have been filed, or that have been patented on behalf of NASA, are available for royalty-free licensing to American firms."

as on the better known work of a close associate. This attitude, however, appears to be diminishing as a result of successful experience with new technology harvested from the work of others. The second problem stems from the fact that large companies — which usually have marketing organizations and production equipment aimed primarily at their existing products — can undertake to add to or modify their marketing organizations and production equipment only for inventions which promise large sales volume. Small companies, which may not have capital already committed in such ways, can naturally be more aggressive toward opportunities for growth.

Obviously, government ownership of patents on inventions made under NASA contracts is undesirable to the contractors who would otherwise own

them. The benefit of such a policy is that NASA freely publishes the information these inventions contain, and offers free licenses to use the inventions. The managements of private companies are not equally free to publish or license, without charge, inventions which may constitute a valuable part of the property of their stockholders. Since NASA is not a private concern, it can keep its wares on display and encourage their free use. **A**

Inquiries concerning NASA patent policy and the licensing of NASA-owned inventions may be directed to the NASA Patent Counsel at any NASA field installation, or to the Assistant General Counsel for Patent Matters, NASA, Washington, D.C. 20546.

AEROSPACE MANAGEMENT
GENERAL ELECTRIC COMPANY □ AEROSPACE GROUP



Complimentary copies or subscriptions to this publication may be obtained by addressing requests on organization letterhead to: Editor
Aerospace Management, Room M-3128, General Electric Company, Valley Forge Space Technology Center, P.O. Box 8555, Philadelphia, Pa. 19101

